



Metritape™

Hastelloy Level Sensor LA-HS

Features:

- **Hastelloy construction provides excellent chemical compatibility**
- **Proprietary laser welding process delivers years of service in demanding environments**
- **All electric resistance-tape sensor for stable output; no moving parts to stick or break**
- **Tank top mounted for easy installation**
- **Virtually maintenance-free**
- **Intrinsically safe**
- **Can combine level and temperature capability in a single sensor**
- **Wide operating temperature range**

Description:

The LA-HS level sensor is used to gauge petroleum products and many chemicals with temperatures up to 107°C (225°F).

The LA-HS level sensor is available in overall lengths of 1 to 36 meters (3 to 120 feet). It has a high resolution helix and gold-on-gold electric contacts for 5 mm (1/4") turns resolution and long-term contact stability. The LA-HS is enclosed in a Stainless Steel (316) channel for physical protection. The filter assembly protects the sensor from moisture and contaminants and provides pressure equalization.

Optional temperature detection can be included in this model with up to three (3) RTD detectors mounted within the sensor envelope at specified locations.

The LA-HS may not be suited for use in some chemicals, caustics, high vapor-pressure materials, or under cryogenic or high level nuclear radiation conditions. Check factory for details.

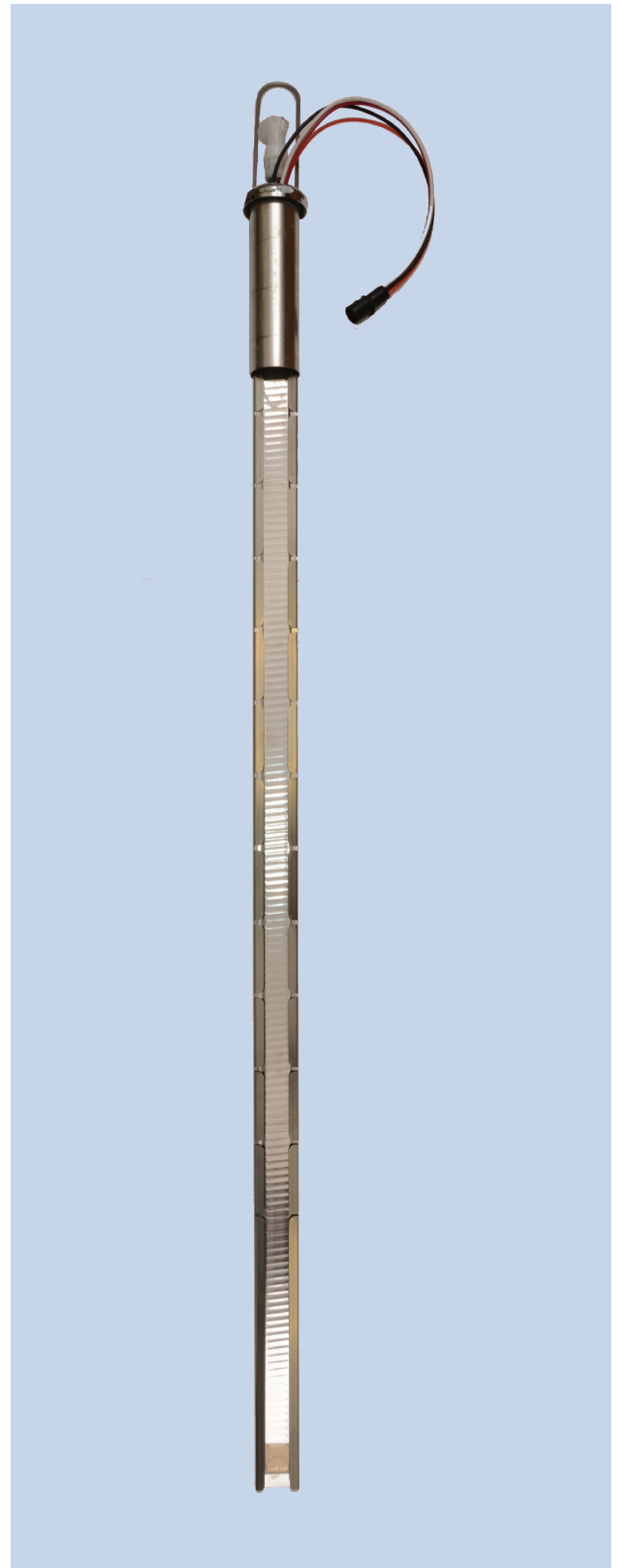

Metritape™ Hastelloy Level Sensor Type LA-HS

Operation Principle:

The resistance-tape sensor's outer envelope jacket (1), is compressed by hydrostatic pressure causing the gold plated nichrome wire helix to contact the stainless steel base strip (2). The resulting resistance (3) indicates the length of active or uncontacted helix, and the distance from sensor top to liquid surface.

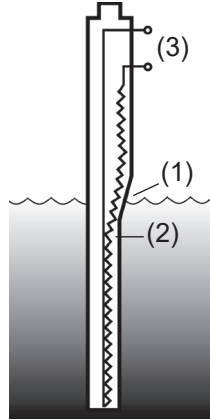

Installation:

The LA-HS sensor is installed into a customer supplied, vented stillpipe with a minimum inside diameter of 40 mm (1.55 inches). Specific stillpipe construction may vary with application.

To Specify Length - (1) Select stillpipe in feet or meters; (2) Specify sensor of same length as stillpipe; (3) LS = LP and stillpipe will extend beyond sensor by 45 mm (1 3/4 inches), the height of close nipple.

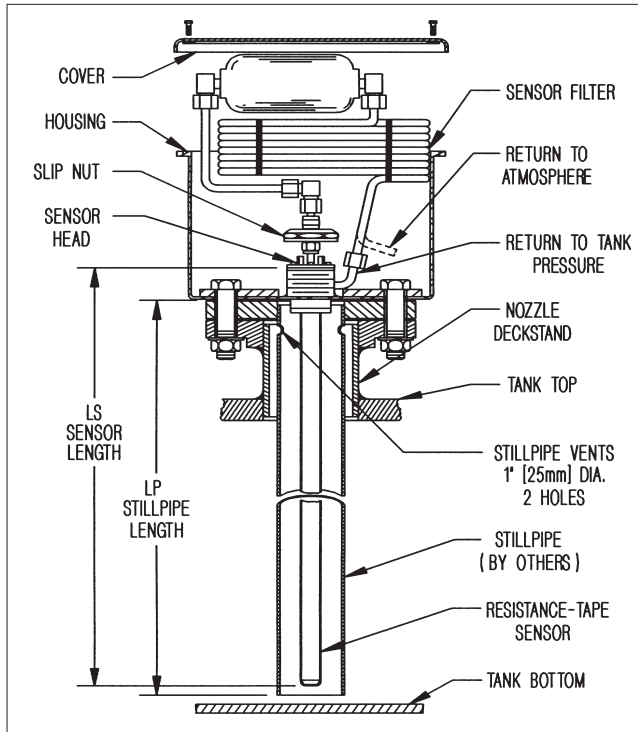

Technical Data:

Sensor Length: 1 to 36 meters or 3 to 120 feet

Temperature Range: -15° to 107°C (5° to 225°F)

Wetted Materials: Hastelloy C276, 304 Stainless Steel and 316 Stainless Steel Channel

Active Helix: Starts 160 mm (6.3 in) from sensor zero, extends to approximately 70 mm (2.7 in) from sensor bottom

Helix Resolution: 5 mm (1/4 inch)

Actuation Depth: Nominal 180 mm (7.1 inch) head of water, offset at calibration

Specific Gravity Effect: 1% increase in SG causes nominal 1.8 mm increase in indicated level, (can be calibrated)

Resistance Gradient: 1000Ω/meter (305Ω/ft), ± 1.5% Actual value supplied and effect removed at calibration.

Helix Temperature Coefficient: 40 ppm/°C

Frequency Response: 0 to 0.1 Hz at 1 m amplitude

Sensor Filter: Polypropylene, HDPE and Acetal. Filter life of 24 to 48 months, depending upon application and level cycle activity.

Pressure Equalization: Direct equalization ± 1 atm

Temperature Detectors: Up to three RTDs per sensor, 2-wire 1000Ω platinum (TP). Located .6 m (2.0') from bottom, 3 m (9.8') from sensor top, and at 50% of sensor length.

Approvals: When used with approved zener barrier, sensor is intrinsically safe. FM: Class I, Division 1, Groups C, D.

Sensor Weight: .5 kg (1.1 lb), plus .24 kg/m (.15 lb/ft)

Sensor Shipment/Storage: Generally coiled on paperboard reel and packed in corrugated box 107 x 107 x 8 cm (42 x 42 x 3 in.). Packing with reel and box adds 3.0 kg (6.5 lbs.) to sensor weight.



JOWA USA, INC.
Littleton, MA 01460-1431

Tel: 978-486-9800
E-mail: info@jowa-usa.com

Web Site: www.jowa-usa.com