



Aquatape™

Level Gauge for Water and Wastewater

Features:

- Complete level gauging package for all water and wastewater applications
- All electric resistance-tape sensor for stable output; no moving parts to stick or break
- Tank top mounted for easy installation
- Virtually maintenance-free; just a five-minute filter change every 24 to 48 months
- Transmitter is completely field adjustable
- Intrinsically Safe - FM approved
- Combined level and temperature capability
- Stillpipe not required in non-agitated applications

Description:

The Aquatape Level Gauge is a packaged system for monitoring level in water and water-based noncorrosive materials. Applications include rivers, reservoirs, wells, waste water, potable water, sea water and municipal sludge.

The Aquatape system consists of the unique resistance-tape sensor, a compact filter assembly, a sensor housing and a 4-20mA current transmitter. It is available in overall lengths of 3 to 50 feet (1 to 15 meters). The filter assembly protects the sensor from moisture and contaminants and provides pressure equalization. The PVC sensor housing mounts to a 1 1/2 inch male pipe thread.

Temperature monitoring can be added to Aquatape at a specified location along the sensor back. Detectors are 1000 ohm platinum. Aquatape is not suited for temperatures above 140°F (60°C), corrosive materials or pressurized applications.



Aquatape™ Level Gauge for Water and Wastewater

Operation Principle:

The resistance-tape sensor's outer envelope jacket (1), is compressed by hydrostatic pressure causing the gold plated nichrome wire helix to contact the stainless steel base strip (2). The resulting resistance (3) indicates the length of active or uncontacted helix, and the distance from sensor top to liquid surface.

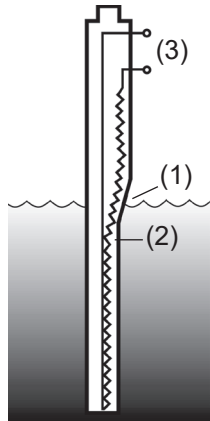

Installation:

The sensor can be installed into a customer supplied, vented stillpipe with a minimum diameter of 1.5 inches. Specific stillpipe construction may vary with application. For non-agitated applications a weight may be affixed to the back side of the sensor eliminating the need for a stillpipe. Contact the factory for additional details.

To Specify Length - (1) Select Aquatape sensor that is greater than height of tank, generally 1 foot greater. (2) Make still pipe 2" (50mm) longer than sensor.

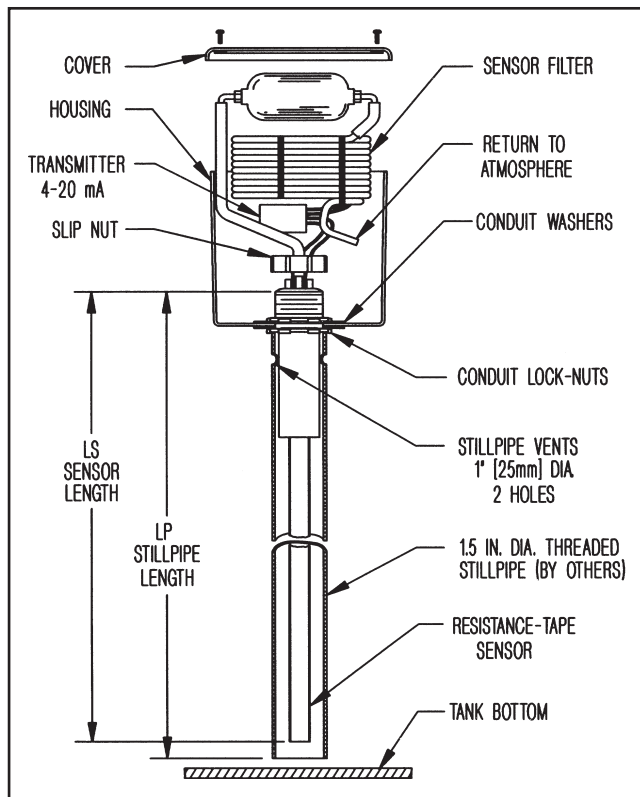

Specifications:

Sensor Overall Length: 3 to 50 feet or 1 to 15 meters.

Operating Temperature Range: 5° to 140°F (-15° to 60°C).

Wetted Materials: Polypropylene, Stainless Steel, Glass-filled Polypropylene. Slip nut is Polypropylene.

Active Helix: Starts 10.6 in. (270mm) from sensor zero, extends to approx. 1.6 in. (40mm) from sensor bottom. Sensor must extend a minimum of 6 in. (152mm) above maximum liquid level.

Helix Resolution: 1/4 inch (5mm).

Actuation Depth: Nominal 5.71 inch (145mm) head of water, offset at calibration.

Specific Gravity Effect: 1% increase in SG causes nominal .05 in. (1.25mm) increase in indicated level, (can be calibrated).

Resistance Gradient: 305Ω/foot (1000Ω/meter), ± 1%.

Helix Temperature Coefficient: 50 ppm / °C.

Frequency Response: 0 to 0.1 Hz at 1m amplitude.

Sensor Filter: Polypropylene and neoprene construction. Filter life of 24 to 48 months, varies with level cycle activity.

Sensor Housing: PVC, 6 x 6 x 6 inch (153 x 153 x 153mm), one central mounting hole drilled, 2 in. dia. (51mm). Conduit / drainage holes drilled by customer.

T-800 Series Current Transmitter: Compact, two-wire, 4-20mA innage output. Receives nominal 24VDC excitation from others. Span and Zero adjusted by internal DIP switches and potentiometers. Transmitter stability is 0.001% / °F. FM approved: Class I, Division 1, Groups C, D. Entity Parameters: V Max = 32V, I Max = 120mA, Ci = 0.24 μF, Li = 0.0 mH. CSA approval available.

Temperature Detector (Option) : One, 2-wire 1000Ω platinum RTD.

System Weight: 8.7 lb. (3.95kg.), plus .15 lb/ft. (.24kg/m).

Sensor Shipment/Storage: Generally coiled on paper-board reel and packed in corrugated box 42 x 42 x 3 in. (107 x 107 x 8cm). Packing adds 8 lbs. (3.63 kg.) to sensor weight.



JOWA USA, INC.
Littleton, MA 01460-1431

Tel: 978-486-9800
E-mail: info@jowa-usa.com

Web Site: www.jowa-usa.com