

Installation and User's Guide

Wireless Base Radio (WBR)

M356 Rev D

August 2006

**JOWA Consilium US, Inc.
59 Porter Road
Littleton, MA 01460-1431**

**Phone: 978-486-9800
Fax: 978-486-0170**

Base Radio

Model: WBR

Versions 1.70 or later

Important Information for the User

- Changes or modifications not expressly approved by JOWA Consilium US, Inc., may void the user's authority to operate the equipment.
- This device complies with Part 15 of the FCC Rules. Operation is subject to the following two conditions:
 - 1 This device may not cause harmful interference.
 - 2 This device must accept any interference received, including interference that may cause undesired operation.
- This device is for mobile and fixed use only (not portable or body-worn). A separation distance of 20 cm must be maintained at all times between the antenna and the body of the user and bodies of nearby persons.
- If the WIM (RF Server) software is shutdown, the RS-485 network **MUST** be physically disconnected from the PC as the serial port is no longer being controlled by the software and may disrupt communications between multiple Base Radios.
- This device has been designed to operate with an antenna having a maximum gain of 9 dBd. Any antenna having a higher gain is strictly prohibited per regulations of Industry Canada. The required antenna impedance is 50 Ohms.
- To reduce potential radio interference to other users, the antenna type and its gain should be so chosen that the EIRP (Equivalent Isotropically Radiated Power) is not more than that required for successful communication.
- The installer of this radio equipment must ensure that the antenna is located or pointed such that it does not emit RF field in excess of Health Canada limits for the general population; consult Safety Code 6, obtainable from Health Canada's website www.hc-sc.gc.ca/rpb.

FCC Certification

- This product is a frequency hopping RF transceiver module for the 900 MHz ISM band, designed to meet FCC 15.247, and is used in industrial control and monitoring applications.
- The antenna is factory installed and **MUST NOT** be removed or modified by user.

This document cannot be changed without prior FM approval

JOWA Consilium US, Inc. reserves the right to update or change this user guide at anytime. For the most recent version of the user guide, please check our website:
www.jowa-consilium.com

© JOWA Consilium US, Inc., 2006.

Printed in the USA

Rev	Date	Notes	Initials
0405	4/22/2005	Updated format, cover, drawings	TH
0505	5/24/2005	Updated Modbus registers	TH
0705	7/21/2005	Converted to Word, removed AO references	TH
0806	4/17/06	Updated for 1.70	CW

Table of Contents

TABLE OF CONTENTS	III
TABLE OF FIGURES	V
1 INTRODUCTION	1
1.1 USING THIS MANUAL	1
1.2 ABOUT THE DEVICE.....	1
1.3 UNPACKING	2
1.4 SOFTWARE COMPATIBILITY.....	2
2 QUICK START	3
3 INSTALLATION	5
3.1 MECHANICAL INSTALLATION.....	5
3.1.1 Base Radio Positioning	5
3.2 ELECTRICAL INSTALLATION	7
3.2.1 Electrical Specifications	7
3.2.2 Wiring Power to the Base Radio	9
3.2.3 Wiring RS-485 to the Base Radio	10
3.2.4 Wiring the Universal Interface Module	11
3.2.5 Wiring the RS-485/232 Converter to the Base Radio	11
3.2.6 Wiring the RS-485/USB Converter to the Base Radio.....	12
3.2.7 Daisy-Chaining Multiple Base Radios to Single RS- 485/Power	13
3.2.8 Base Radio Output Modules	15
3.2.9 Terminating Communications Wiring to the Base Radio	15
3.2.10 Grounding the Base Radio	16
3.2.11 High Gain Antenna	16
4 GENERAL CONFIGURATION	17
4.1 BASE RADIO DISPLAYED MESSAGES	17
4.1.1 The Read Only Sequence.....	17
4.2 OVERALL CONFIGURATION MENU MAP.....	18
4.3 SETTING THE USER PASSWORD.....	19
5 CONFIGURING THE RF COMMUNICATIONS	20
5.1 RF CHANNEL SELECTION	20
5.2 RF BAUD RATE SELECTION.....	21
5.3 HIGH RF ID SETTING.....	21
6 CONFIGURING THE MODBUS COMMUNICATIONS	23
6.1 BASE RADIO SETUP	23
6.1.1 Modbus Baud Rate Setting	23
6.1.2 Modbus Device ID Setting.....	24
6.1.3 Modbus Parity Setting	26
6.1.4 Modbus Mapping Mode Setting	26
6.2 MODBUS COMMUNICATION PROTOCOL.....	27
6.3 MODBUS COMMANDS	28
6.3.1 Command 03-Read Holding Registers	28
6.3.2 Command 08- Diagnostic.....	28
6.3.3 Command 11- Get Com Event Counter	29

6.3.4	Command 12- Get Com Event Log.....	29
6.3.5	Command 17- Report Slave ID	29
6.3.6	Command 43- Read Device ID	30
6.4	BASE RADIO HOLDING REGISTERS.....	30
6.4.1	Base Radio Device Type Registers	31
6.4.2	Base Radio Device Status Registers	31
6.4.3	Base Radio On/Offline Field Unit Registers.....	31
6.5	FIELD UNIT HOLDING REGISTERS.....	32
6.5.1	Device ID Mapping Mode.....	32
6.5.2	Register Mapping Mode	32
6.5.3	Field Unit Device Type Holding Registers	33
6.5.4	Field Unit Device Status Registers	34
7	TECHNICAL SPECIFICATIONS	35
APPENDIX A	NAVIGATING THE MENUS	37
APPENDIX B	BASE RADIO MENU MAP	38
APPENDIX C	MODBUS REGISTER DEFINITIONS.....	39

Table of Figures

Figure 2-1 Overall Wiring Schematic.....	3
Figure 3-1 General Layout.....	6
Figure 3-2 Overall Wiring Schematic.....	8
Figure 3-3 Terminal Block Labels.....	9
Figure 3-4 Wiring Power to the Base Radio.....	10
Figure 3-5 Wiring RS-485 to the Base Radio.....	10
Figure 3-6 Base Radio to RS-232 Converter Wiring Diagram.....	11
Figure 3-7 Daisy-Chaining Power to Multiple Base Radios.....	14
Figure 3-8 Daisy-Chaining RS-485 to Multiple Base Radios.....	14
Figure 3-9 Example of End Unit in Daisy-Chain Configuration.....	15
Figure 3-10 Example of Correct Termination Resistor Setup.....	16
Figure 4-1 Base Radio Power-Up and Operations LCD Sequences.....	17
Figure 4-2 The Read Only Sequence.....	18
Figure 4-3 Overall Configuration Menu Map.....	18
Figure 4-4 Menu Map to Password Setting.....	19
Figure 5-1 Menu Map to RF Channel Setting.....	20
Figure 5-2 Menu Map to RF Baud Rate Setting.....	21
Figure 6-1 Menu Map to Modbus Baud Rate Setting.....	24
Figure 6-2 Menu Map to Modbus Device ID Setting.....	25
Figure 6-3 Menu Map to Modbus Parity Setting.....	26
Figure 6-4 Menu Map to Modbus Mapping Mode Setting.....	27
Figure 7-1 Overall Base Radio Dimensions.....	36

1 Introduction

1.1 Using this Manual

This manual is designed to assist in installing, operating, and maintaining the JOWA Consilium Model WBR Base Radio. The manual is broken into sections as follows:

2 Quick Start

This section summarizes what must be done in order to get the device installed, configured, and in operation quickly. However, it does not provide detailed or how-to information to perform the tasks outlined.

3 Installation

This section explains mechanical installation and correct wiring for power and communications. Also covered in this section are instructions for “daisy-chaining” multiple Base Radios together on the same power and communications supplies. Proper termination of the communications is also covered.

4 General Configuration

In this section the general configuration options such as password protecting, and selecting a user password are discussed. Also covered is the importance of the Number of Wireless Instruments (HI RFID) setting, as well as the configuring of this setting.

5 Configuring the RF Communications

This section covers the setup of the Base Radio RF Communications that allow the Base Radio to communicate with Field Units that have been placed in service.

6 Configuring the MODBUS Communications

This section only applies if you have purchased the Modbus Base Radio (WBR-I-XP-MOD). This section covers the various Base Radio settings that must be configured for Modbus communication such as baud rate, parity, device ID's, and register mapping modes. Also covered in this section is a brief discussion of the Modbus communications protocol and Modbus commands that are used with this device.

Modbus register locations are also discussed within this section.

7 Technical Specifications

This section explains the technical specifications that are associated with this device, such as power characteristics, accuracy, and operating characteristics.

1.2 About the Device

The JOWA Consilium Base Radio is a reliable Radio Frequency (RF) transceiver with a variety of available outputs contained in an explosion proof housing useable in many hazardous and hard-to-reach areas. The time and expense of running wires often makes it difficult to measure parameters that have an economic impact on your plant operation, but the Base Radio allows you to quickly and accurately monitor those devices at a fraction of the cost, giving you bigger and faster returns on your instrumentation investments.

The Base Radio communicates in a secure, frequency digital protocol over a band of frequencies from 902 MHz to 928 MHz. These devices do not require permits or licenses and are easily setup and installed right out of the box.

The JOWA Consilium Base Radio may be used to communicate with many Field Units in various applications. You can use this device for long-term monitoring in remote locations, for short-term data gathering on process conditions, or to quickly test the economic viability of a new installation.

The purpose of this guide is to help you install, configure and maintain your JOWA Consilium Base Radio.

1.3 Unpacking

Remove the Packing List and check off the actual equipment received. If you have any questions about your shipment, please call your JOWA Consilium Representative. Upon receipt of shipment, inspect the container for any signs of damage in transit. Especially take note of any evidence of rough handling. Report any apparent damage immediately to the shipping agent.

Please note that sometimes units are assembled with accessories when shipped. Inspect the shipment carefully if you think that something is missing. This is rare, as we take considerable care to pack units for shipment, but it does sometimes happen. Please give us a call and we may be able to resolve this matter quickly over the phone.

Please note that the carrier will not honor any claims for damage unless all shipping materials are saved for their examination. If you find any damage while you are examining and removing the contents, save the packing material and the carton.

1.4 Software Compatibility

Software for JOWA Consilium is revised periodically. Internal device software may contain portions that are not compatible with previous versions of Wireless Instrumentation Manager software (WIM).

To ensure software compatibility, WIM version 1.70.138 or later must be used. If you believe you are experiencing software compatibility issues please call JOWA Consilium Customer Service at (978) 486-9800 or email info@jowa-consilium.com.

2 Quick Start

This section summarizes what must be done in order to get the device installed, configured and in operation quickly. Additional detailed information is found throughout this guide. Steps 1-3 refer to the following diagram:

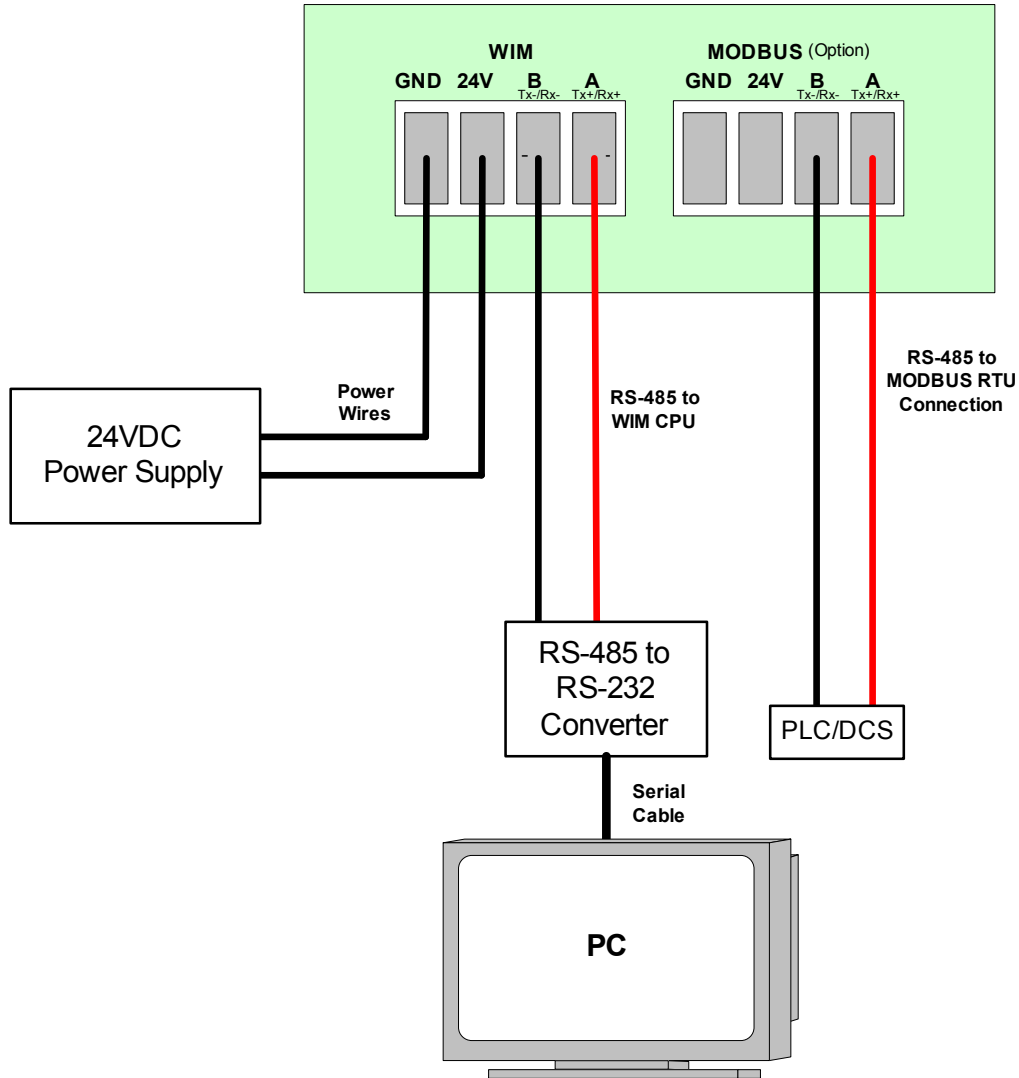

Figure 2-1 Overall Wiring Schematic

1. Wire 24VDC power to the Base Radio using the power terminals on either the WIM or the Modbus connection. Do not apply power to both sets of terminals.
2. Wire WIM RS-485 communications to the left terminal of the Base Radio.
3. Wire Modbus RS-485 communications to the right terminal of the Base Radio (WBR-I-XP-MOD only).
4. Place the terminating resistor between terminals A and B if the Base Radio will be used as an End Unit (See Section 3.2.9).

5. The Base Radio RF settings should be configured as follows:
 - Set the RF Channel to any available RF CHAN that matches the one used by the Field Units you wish to communicate with (other than RF OFF).
 - Set the Baud Rate to 76.8 K or to the Baud Rate used by the Field Units with which you wish to communicate.
 - HI RF ID = the highest field unit RF ID you assign to this network.
6. Configure the Modbus settings (WBR-I-XP-MOD only)
7. Verify “COMM OK” message on Base Radio LCD screen

If you are not receiving a “COMM OK” message on the Base Radio check the following:

- Is the Base Radio set to the above listed configurations?
- Are all the Field Units on?
- Are the Field Units set to the matching RF configurations (see Section 5 of Field Unit and Base Radio User Manuals)?
- Are the Base Radio and Field Units unable to communicate due to obstructions or distance (see Field Unit Manual: Field Unit Placement section)?



Warning! If the Field Units have been running for an extended period of time with no signal from the Base Radio (the Base Radio is off or not present), the Field Units will only search for the Base Radio every one hour or so. Turning the Field Units off and back on will cause them to begin searching immediately.

3 Installation

This section discusses both the mechanical and electrical aspects of installation. It is divided into the following sections:

- 3.1: Mechanical Installation
- 3.2: Electrical Installation

3.1 Mechanical Installation

In this section, the mechanical installation instructions are discussed for the various setup capabilities of the Base Radio. The subsections are as follows:

3.1.1 Base Radio Positioning

The JOWA Consilium Base Radio is a rugged device, which provides optimal performance when installed with careful consideration. Installation practices greatly affect the life that you can expect from your JOWA Consilium Base Radio. The main considerations for installation are covered below.

Give careful consideration to the environment where you will be installing the devices. Avoid installations that expose the device to excess temperature, high vibration, considerable shock, or exposure to dripping condensate or corrosive materials. Also avoid installing the device in an unserviceable location.

Most often these problems can be avoided with some thought at the time of installation. The practices noted below are generally recommended, but they can only act as guidelines and cannot cover all possible variations.

The final installation must be made at the discretion and approval of the user. You must be the judge of the actual installation.



Warning! During installation do not apply force to the instrument housing or antenna. Use a proper wrench for all installations. Failure to use correct installation procedures can cause damage to the Base Radio.

3.1.1 Base Radio Positioning

Correct positioning of the Base Radio will ensure the best performance of the device. Because the Base Radio is the central communication device of all Field Units that are assigned to it, the Base Radio should be located in an area that is somewhat central to all of the Field Units.

Figure 3-1 is a picture of a general Base Radio layout. The maximum distance is determined by a number of factors, including the Baud Rate Setting. When planning the positioning of the Base Radio, try to place the Base Radio in a location with an unobstructed view to the most Field Units possible.

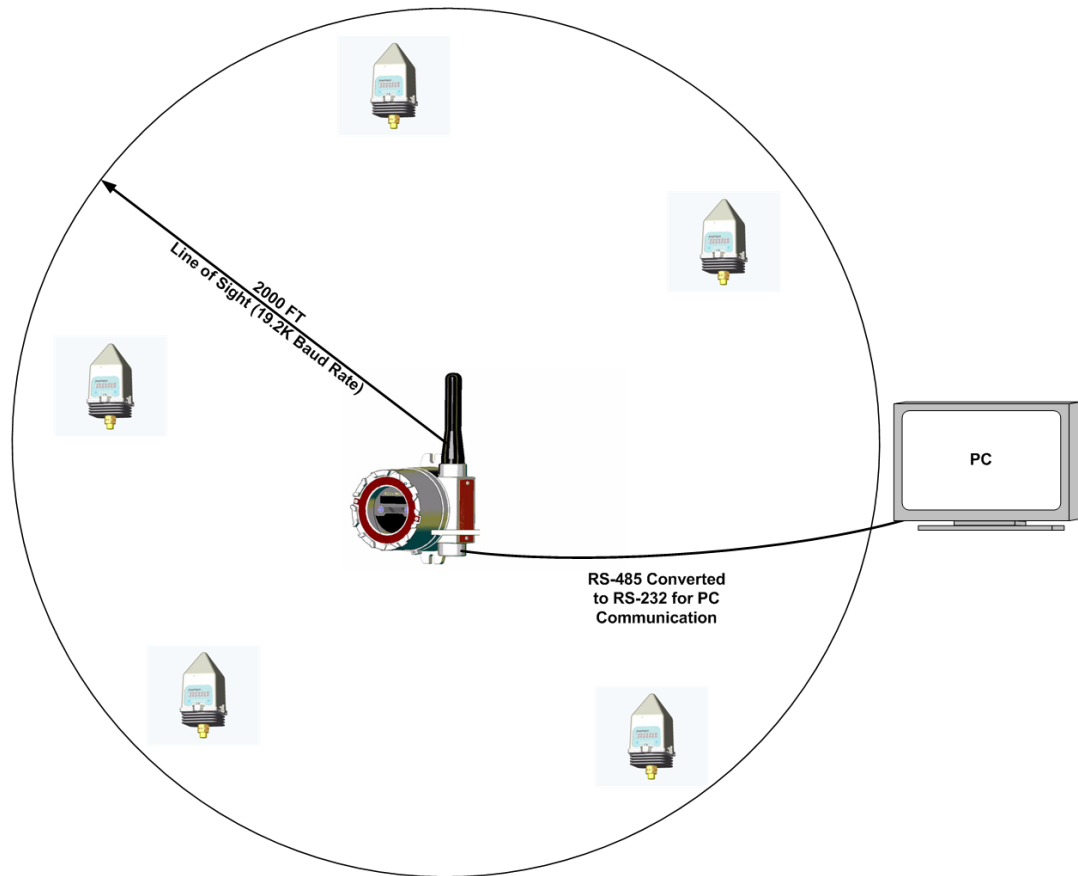

Figure 3-1 General Layout

Remember, the approximate line of sight range between a Field Unit and Base Radio is determined by the Baud Rate as listed below:

- 76.8K - 76.8 Kbaud, Range of 500 to 750 ft
- 19.2K - 19.2 Kbaud, Range of 2,000 to 2,500 ft
- 4.8K - 4.8 Kbaud, Range of 3,000 ft



Note This range is reduced by the amount of RF Noise present, obstructions, and the material properties of those obstructions.

Only place the Base Radio in ambient operating temperatures of -40°F to 185°F (-40°C to 85°C).

Make sure you have power and communication to the Base Radio available (see 3.2 Electrical Installation).

Because there are so many setup possibilities we cannot cover them all. A correct setup would make sure that the above warnings are heeded and that the Field Unit and Base Radio are capable of communication. The RF Placement Procedure section of the Field Unit Guide will help you to determine if you have a selected the correct installation points and orientations for your application.

3.2 Electrical Installation

In this section wiring instructions are discussed for the various setup capabilities of the Base Radio. The subsections are as follows:

- 3.2.1 Electrical Specifications
- 3.2.2 Wiring Power to the Base Radio
- 3.2.3 Wiring RS-485 to the Base Radio
- 3.2.4 Wiring the Universal Interface Module
- 3.2.5 Wiring the RS-485/232 Converter to the Base Radio
- 3.2.6 Wiring the RS-485/USB Converter to the Base Radio
- 3.2.7 Daisy-Chaining Multiple Base Radios to Single RS-485/Power
- 3.2.8 Base Radio Output Modules
- 3.2.9 Terminating Communications Wiring to the Base Radio
- 3.2.10 Grounding the Base Radio
- 3.2.11 High Gain Antenna



Warning! Remember to turn off all power BEFORE attaching the Base Radio wires!

3.2.1 Electrical Specifications

- 24VDC Power Supply with 0.5 Amp minimum output
Recommend 22AWG Power Supply wire
- 2 Wire RS-485 Serial Communications Cable
Recommend Belden 3105A shielded and protected 22AWG or equivalent
- 120 Ohm, $\pm 5\%$, $\frac{1}{4}$ W resistor for RS-485 termination
- RS-485 to RS-232 converter B&B model 485LDRC9 or equivalent
- 8 AWG bare or green covered grounding cable for housing ground

In Figure 3-2, an overall wiring schematic is shown. Note that the grounding screw is located on the outside of the Base Radio housing.

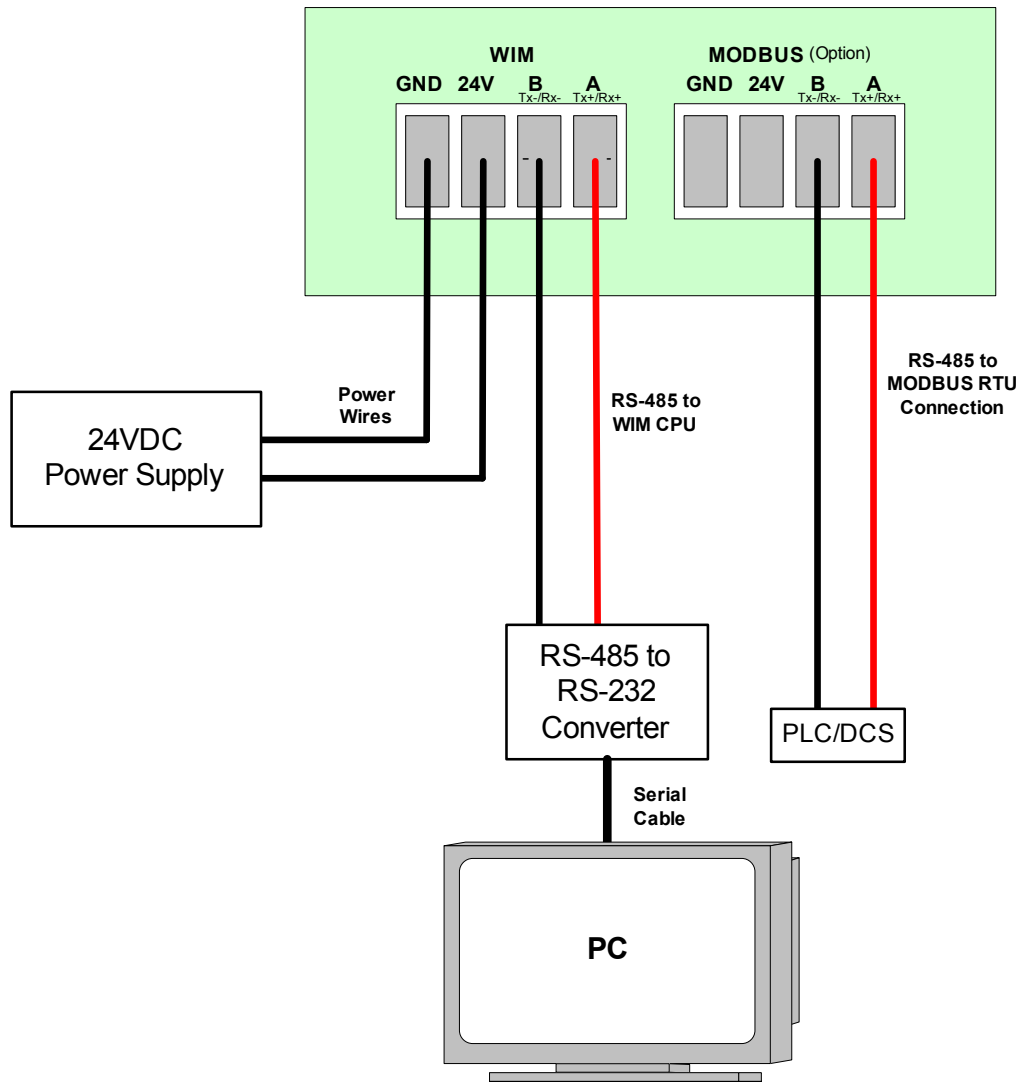

Figure 3-2 Overall Wiring Schematic



Warning! Explosions may result in death or serious injury. Do not remove the instrument cover in explosive atmospheres when power and/or communications are on.

To begin the electrical installation first remove the explosion proof housing cover from the Base Radio, if you have not already done so. Point the Base Radio antenna away from you and look at the green PC Board found directly underneath the NEXT and ENTER buttons. You should see two terminal blocks and some labels as shown in Figure 3-3.

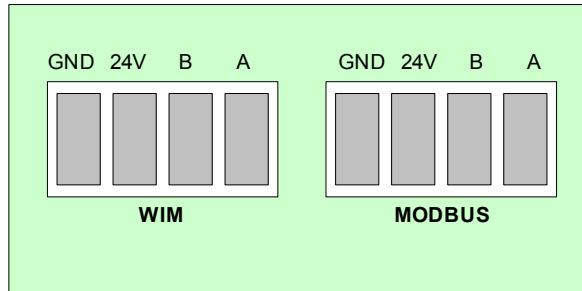

Figure 3-3 Terminal Block Labels

Once you have located these terminal blocks you can wire the Base Radio accordingly. The best way to wire the Base Radio is to:

- Remove both terminal blocks from the jacks on the Base Radio
- Insert the wire through the conduit hole on the bottom right of the Base Radio
- Secure the wire into the proper terminal blocks
- Then plug the terminal blocks back into the proper jacks on the Base Radio.



Warning! If the Field Units have been running for an extended period of time with no signal from the Base Radio (the Base Radio is off or not present), the Field Units will only search for the Base Radio every one hour or so. Turning the Field Units off and back on will cause them to begin searching immediately.

3.2.2 Wiring Power to the Base Radio

The JOWA Consilium Base Radio is designed to use a 24 VDC power supply at a minimum of 0.5 Amps. JOWA Consilium offers a DIN rail mountable 100-240VAC 50/60Hz to 24VDC transformer for this purpose. For more information, contact your JOWA Consilium Representative.

The Common or Negative wire should be placed in the left most slot labeled “GND” on the PC Board of the terminal block in Figure 3-4. The Positive wire should be placed in the same terminal block in the slot labeled “24V” on the PC Board as shown in Figure 3-4.

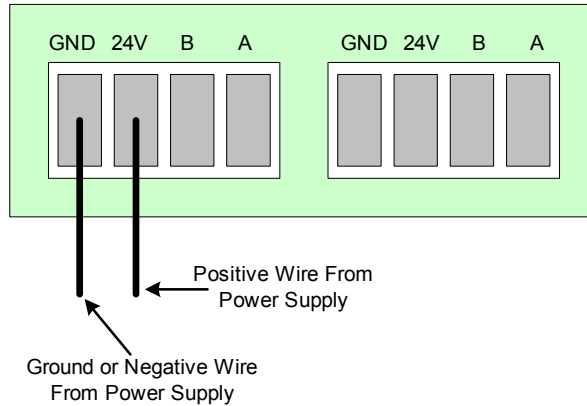

Figure 3-4 Wiring Power to the Base Radio



Caution! Make sure only **ONE** power supply is routed to the Base Radio at any time!

3.2.3 Wiring RS-485 to the Base Radio

The Base Radio also requires a half-duplex RS-485 bus to be wired for communications. Wiring communications to a PC in order to run the Wireless Instrumentation Manager (WIM) software may require the use of an RS-485 to RS-232 converter, as most PCs cannot be wired directly to RS-485.

To wire the RS-485 cable to the Base Radio we recommend using a 22AWG twisted pair shielded wire. Place one of the twisted pair wires in the “A” (Tx+/Rx+) slot of the same terminal block as the power supply wires, and the other wire in the “B” (Tx-/Rx-) slot of the terminal block as shown below in Figure 3-5.

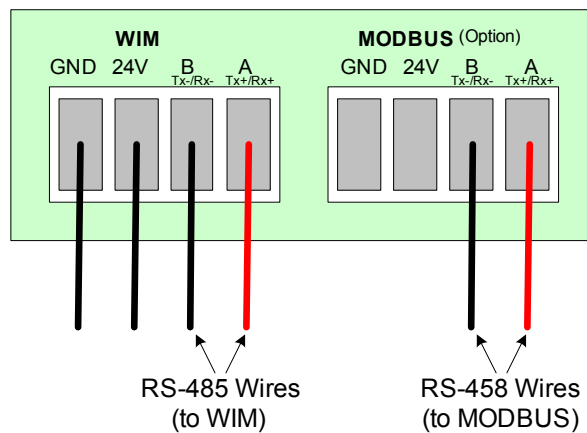

Figure 3-5 Wiring RS-485 to the Base Radio

RS-485 may be wired in-line (in series) to multiple Base Radios. This is called “daisy-chaining”. Only Base Radios using Modbus RS-485 output can be daisy-chained. See Section 3.2.7. Note that Base Radios daisy-chained must be set to different RF Channels to communicate properly on the same wire.

3.2.4 Wiring the Universal Interface Module

JOWA Consilium offers a Universal Interface Module (WI-UIM), also known as the “Smart Cable”. This module is used to connect the Base Radio or the JOWA Consilium Output modules to a personal computer (PC). It provides a connection to a USB port or to an RS232 port.

3.2.5 Wiring the RS-485/232 Converter to the Base Radio

JOWA Consilium offers an optically isolated, surge protected, DIN Rail mountable RS-485/232 converter. Because there are many RS-485/232 Converters available, please see your converter’s instruction manual for details as this section will only discuss the wiring of the B&B 485LDRC9 converter.

The Base Radio communicates via a RS-485 half-duplex differential signal with A being Tx+/Rx+ and B being Tx-/Rx-. To properly wire the Base Radio to the 485LDRC9, you should follow Figure 3-6.

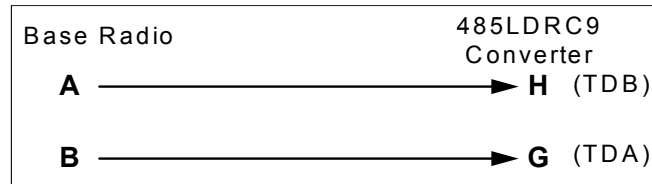

Figure 3-6 Base Radio to RS-232 Converter Wiring Diagram

To configure the 485LDRC9 to the appropriate baud rate (38.4Kbaud), a set of dip switches must be configured. These switches can be found on the side of the converter. The first four switches should be in the ON position to indicate that the communications are half-duplex. The fifth switch should also be in the OFF position as this activates the 120 Ohm termination resistor within the converter. This terminator is only useful for long RS-485 buses, or other calculated circumstances. Finally, switches six, seven, and eight should be set to the OFF position to indicate the correct baud rate. (Note: An 8.2 K resistor (R11) has been installed at the factory to achieve these higher baud rates. If you did not purchase the converter from the factory, you will need to install the resistor.)

To wire power to the 485LDRC9, place a +10 to 30 VDC supply to terminal F, and place the ground (V-) to terminal C.

The final step in installing the converter is to attach a DB-9 RS-232 (serial) cable from the converter to an available serial port on your computer.



Note The RS-485 bus is half-duplex. If the Base Radio in the application is wired to a RS-485 to RS-232 converter, the A (Tx+/Rx+) and B (Tx-/Rx-) wires may need to be crossed for correct operation. Please see the converter's manual for further instructions.

3.2.6 Wiring the RS-485/USB Converter to the Base Radio



Note The RS-485 cable should **NOT** be connected to the RS-485/USB converter before the converter drivers have been installed.

JOWA Consilium also offers a non-optically isolated RS-485 to USB converter. The USB Converter provides easy connectivity between the PC and standard communication ports, not requiring PC reconfiguration, assignment of IRQs, or jumper settings.

Use of this device requires a PC with a USB port compliant with USB 1.1 or later.

The RS-485 to USB converter is equipped with a USB cable and a USB type A connector for connection to a PC USB port and a male DB-9 for connection to an RS-485 equipped data or communication terminal.

3.2.6.1 USB Driver Installation

1. Power on the PC. Verify the USB port is enabled and insert the CD that has been provided.
2. Connect the USB cable of the converter to the USB port of the PC. Make sure not to have the RS-485 cable plugged into the converter at this time.
3. Windows™ should detect the USB device, and if the driver does not already exist on the PC the “**Add New Hardware Wizard**” will be displayed. Click the **NEXT** button.
4. From this new screen select “**Specify a Location**” and specify the PC's drive letter for the CD-ROM drive where the provided CD has been inserted. Click the **NEXT** button to begin the search.
5. Once the drivers have been located a new screen will be displayed. Click **NEXT** to continue.
6. At this point Windows™ has finished installing the RS-485 to USB converter drivers. Click **FINISH**.
7. Once Windows™ has detected the USB device, click **NEXT**.
8. Now connect the RS-485 cable to the converter's DB-9 terminal.
9. Click **START, SETTINGS, CONTROL PANEL**, then select **SYSTEM**, and click on **DEVICE MANAGER**. Verify that the converter is listed in COM PORTS as “USB to Serial Adapter”.
10. The converter installation is now complete. The PORTS section of the DEVICE MANAGER, mentioned in step 9, shows the new COM PORT number next to the “USB to Serial Adapter”. You need this number to set the WIM's RF Server to look at the correct COM PORT for incoming information.

11. To specify this COM PORT, start the RF Server and **Right-Click** on the RF Server Icon (see the WIM User's Guide, Section 4 for more details). Select **Options**. Then click **ADD** to add the converter's COM PORT. The baud rate should remain at 38400. Then select **OK** and the added port will be displayed. Select **OK**.

3.2.6.2 Wiring the DB-9 RS-485 Cable to the Base Radio

Using the converter's Male DB-9 Connector chart wire up a **Female** DB-9 connector such that Pins 2 and 9 (Tx+ and Rx+) go to the Base Radio's WIM terminal A, and Pins 1 and 3 (Tx- and Rx-) go to the Base Radio's WIM terminal B. (See Figure 3-5 for details on WIM Terminal A and B).

USB Converter's Male DB-9 Connector

PIN #	SIGNAL
1	Rx-
2	Tx+
3	Tx-
4	NC
5	GND
6	NC
7	NC
8	NC
9	Rx+

3.2.6.3 USB Driver Un-installation

1. Unplug the converter from the PC's USB Port.
2. Insert the converter's driver CD used for installation.
3. Run the FTDIUNIN.EXE program.
4. Restart the PC.

3.2.7 Daisy-Chaining Multiple Base Radios to Single RS-485/Power

Two or more Base Radios may be placed on a single RS-485 communication line, and a single power supply line (provided the power supply and wiring can handle the load). This section will provide the information needed to daisy-chain multiple Base Radios. However, be sure to complete Section 3.2.8 on correct Base Radio termination if doing so.

3.2.7.1 Daisy-Chaining Power to Multiple Base Radios

A consideration when daisy-chaining power to multiple Base Radios is the power draw at power supply. Each Base Radio will typically draw 200mA @ 24VDC. This means a single Base Radio will draw a typical average power of 4.2W.

If using the supplied DIN rail mounted 15W power, it is suggested that no more than three Base Radios be tied parallel to this supply.

To daisy-chain two or more Base Radios together, each Base Radio should be wired in parallel to the next while making sure power is not supplied from two separate supplies to any single Base Radio. A typical wiring setup is shown in Figure 3-7 below:

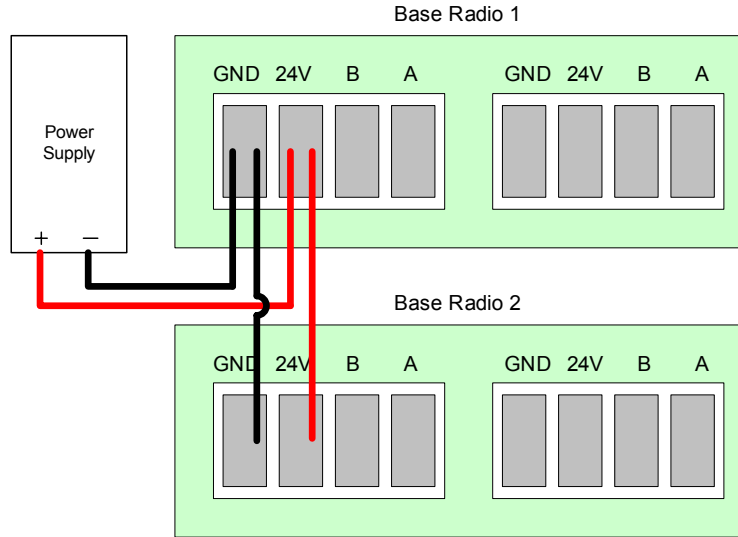

Figure 3-7 Daisy-Chaining Power to Multiple Base Radios

3.2.7.2 Daisy-Chaining RS-485 to Multiple Base Radios

Modbus connections can be daisy-chained together, but WIM connections cannot. There can only be one Base Radio, multiple Output Modules, and a PC on the same WIM RS-485. If you have two Base Radios connected to a PC running WIM, you must have two COM ports.

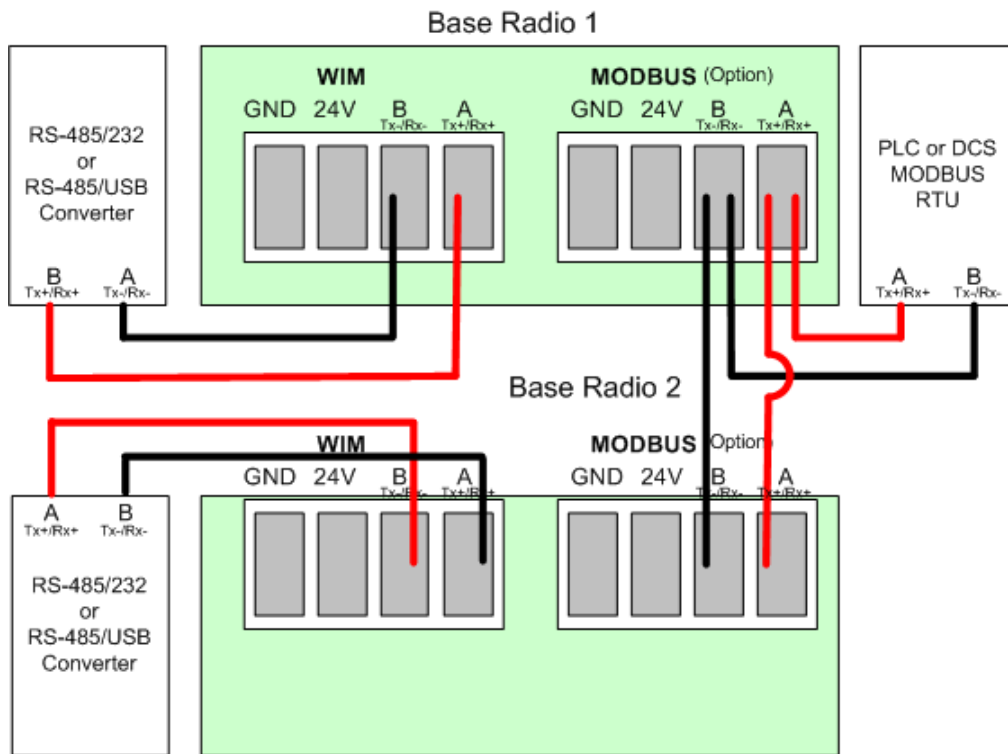

Figure 3-8 Daisy-Chaining RS-485 to Multiple Base Radios

3.2.8 Base Radio Output Modules

Accessories are available for the Base Radio for conventional 4-20mA current loops and switch closures. These products are the WI-4AO, 4 Analog Output Module, the WI-8SW, 8 Switch Closure Module and the WI-4AO-8SW analog, and Switch Closure Output Module. These modules can be used to provide analog signals, switch closures, and to report alarms for diagnostic conditions of the wireless instrumentation network, such as the need for a new battery in a field device.

3.2.9 Terminating Communications Wiring to the Base Radio

RS-485 is capable of maintaining communications over a maximum distance of 4000 feet. In most (and we recommend all) situations the unit that comprises an “end” of an RS-485 network should be terminated by a resistor wired across the A and B wires.

In the case of a daisy-chained application the end unit should be terminated. The end unit is the unit that is located at the end of the series of units. In a PC to Base Radio only application, the end unit is the Base Radio. Note: a PC is also an end unit, but the termination for this end unit is done within the converter. In a multiple unit daisy-chain application the end unit is shown in Figure 3-9.

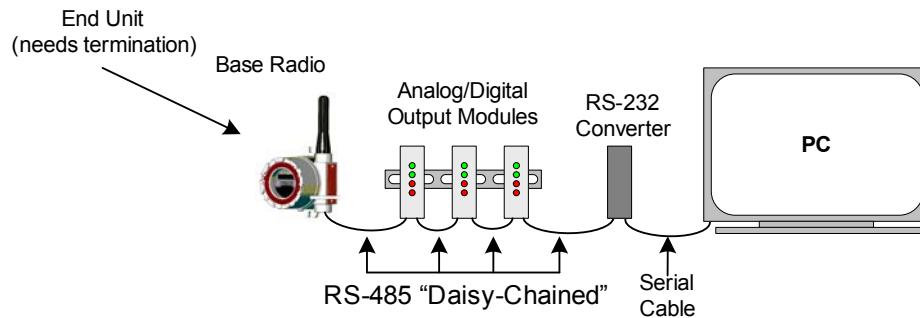

Figure 3-9 Example of End Unit in Daisy-Chain Configuration

Termination of an end unit is done by placing a resistor across the A and B wires of the RS-485 cable. The value of this resistor should match the characteristic impedance (Z_0) of the RS-485 cable. The characteristic impedance (Z_0) is published by the manufacturer of the RS-485 cable you are using. If you are using the Belden RS-485 wire (recommended in section 3.2.1) the value of the resistor should be a 120 Ohm ¼ watt resistor.

To terminate a Base Radio, place one end of the resistor in the open terminal block's B slot and place the other end of the resistor in the open terminal block's A slot. Doing so will place the resistor across the A and B wires, as needed. An example of this is shown in Figure 3-10.

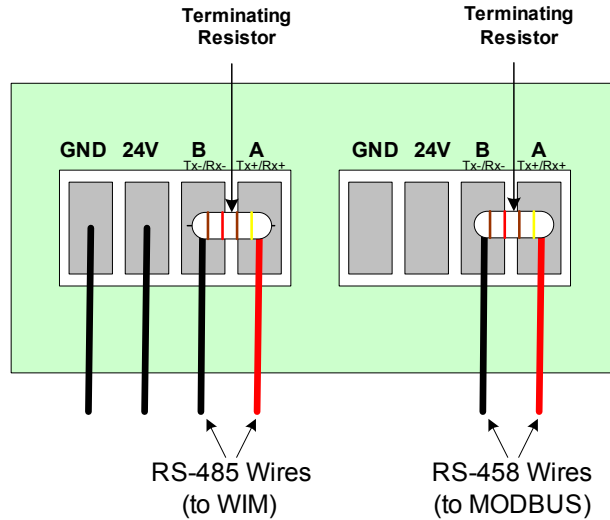

Figure 3-10 Example of Correct Termination Resistor Setup

3.2.10 Grounding the Base Radio

In order to assure safety requirements on your Base Radio, the Base Radio housing must be grounded. We have provided a grounding screw located on the left side of the Base Radio housing. To ground the Base Radio simply place a wire from the grounding screw to a grounded object.

Possible grounded objects include:

- The building's metal frame-work
- Any electrical conduit
- A suitable grounding or lightning rod

3.2.11 High Gain Antenna

A high-gain antenna is available for the Base Radio. This antenna generally doubles the signal range of the Base Radio, but requires an installation in a general-purpose area.

4 General Configuration

This section discusses the generalities around configuring the Base Radio via the NEXT and ENTER buttons. The subsections are as follows:

- 4.1: Base Radio Displayed Messages
- 4.1.1: The Read Only Sequence
- 4.2: Overall Configuration Menu Map
- 4.3: Setting the User Password

4.1 Base Radio Displayed Messages

The Base Radio should be on if power is being supplied (See Section 3.2: Electrical Installation). Upon power-up, the Base Radio will display a Power-Up Sequence, and then go into an Operations Sequence. These Sequences are shown in Figure 4-1 below:

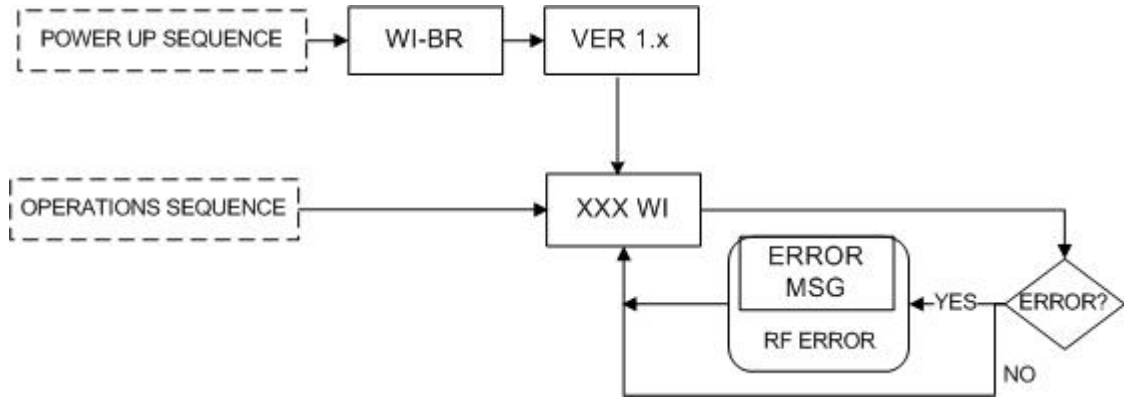

Figure 4-1 Base Radio Power-Up and Operations LCD Sequences



Note During configuration and testing, keep Field Units at least six feet from the Base Radio and other field Units to ensure good communications.

4.1.1 The Read Only Sequence

Once the Base Radio is in the Operations Sequence, a user may access the READ-ONLY Sequence without a password by simply pressing the ENTER button at any time. The Read-Only Sequence, as shown in Figure 4.2, displays extra information about the current settings of the Base Radio that is not seen during the Operations Sequence. No changes may be made to these settings here.

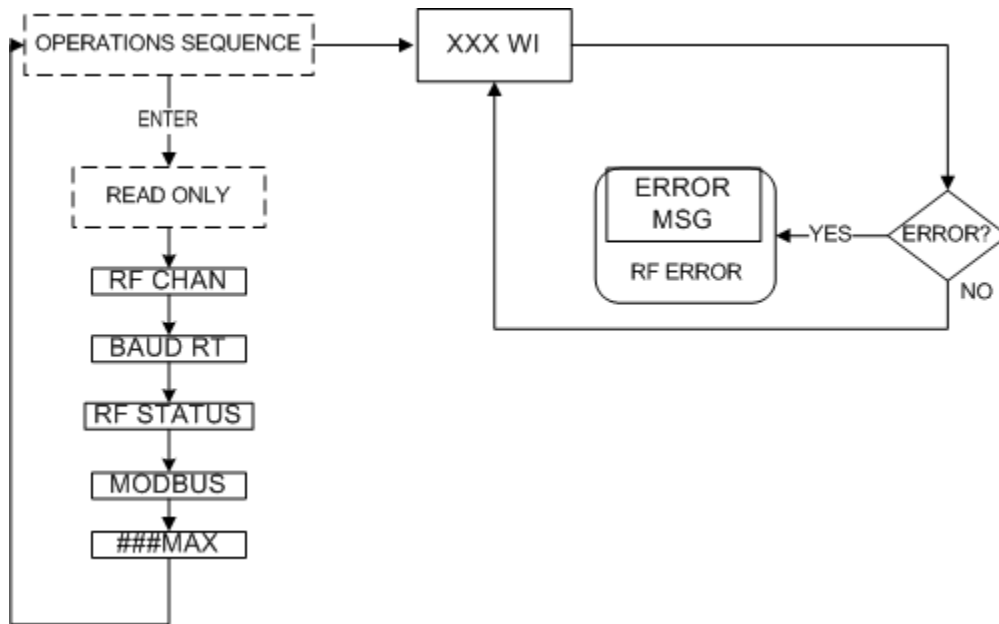

Figure 4-2 The Read Only Sequence

4.2 Overall Configuration Menu Map

A complete Base Radio Menu Map is shown in Appendix B. Below is an overall view of the configuration menu to aid the user in setting up the Base Radio for proper operation.

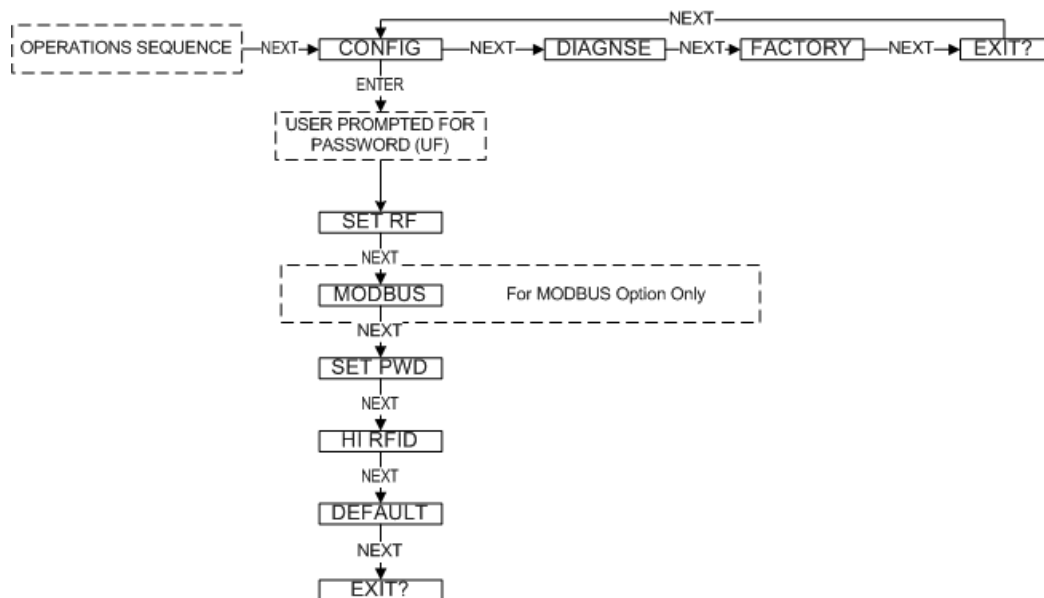

Figure 4-3 Overall Configuration Menu Map



Note The RS-485 is only available if you have ordered to Modbus communication option (WI-BR-I-XPMOD).



Note The user must enter a four digit password to enter the CONFIG and DIAGNSE. The FACTORY menu is for factory use only. The default user password is 0000. For more information on the password see Section 4.3.

4.3 Setting the User Password

Each Base Radio has a password that will lock out undesired users from making changes to the Base Radio. Any user may still view some of the Base Radio settings by pressing the ENTER key during the Operations Sequence and viewing the Read Only Sequence.

The password is a four-digit password. The factory default is 0000. If you wish to select a different password, follow the Base Radio Menu Map shown in Figure 4.5 to change it.

If you forget your password you must call your JOWA Consilium Sales Representative to have it reset.

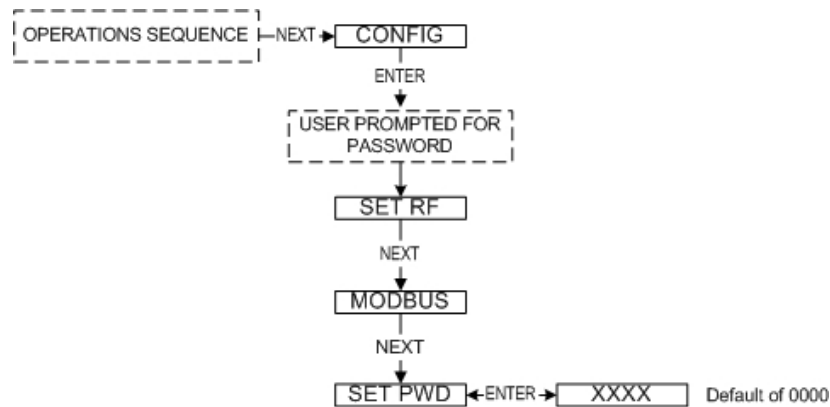

Figure 4-4 Menu Map to Password Setting

5 Configuring the RF Communications

In order for the Base Radio and the Field Unit to communicate they must be on the same RF Channel, and must be transmitting at the same Baud Rate. All Field Units and Base Radios are set to RF OFF default configurations at the factory, and must be field configured for proper operation. The subsections are as follows:

- 5.1: RF Channel Selection
- 5.2: RF Baud Rate Selection
- 5.3: High RF ID Setting



Warning! If the Field Units have been running for an extended period of time with no signal from the Base Radio (the Base Radio is off or not present), the Field Units will only search for the Base Radio every one hour or so. Turning the Field Units off and back on will cause them to begin searching immediately.

5.1 RF Channel Selection

All Base Radios and Field Units can be set to one of 16 different communication channels. The only Field Units recognized by a particular Base Radio are the units that share the same RF Channel as that Base Radio. This allows the user to decide which Field Units communicate with each Base Radio.

Each Base Radio comes from the factory set to the RF OFF channel. This means the Base Radio will not communicate with any Field Units. To set the Base Radio for communication, first determine the channel that you wish to use. To determine which RF Channel to use, you should know if there are any other Base Radios in the same vicinity and then choose a different channel number. After deciding on the RF channel number, then follow the Base Radio menu map shown below in Figure 5-1 to configure the RF Channel.

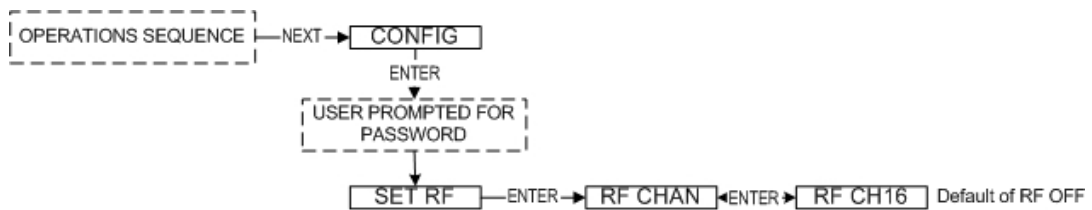

Figure 5-1 Menu Map to RF Channel Setting

Once you are in the RF Channel menu, you can increment it by pressing the NEXT button. When selecting the RF Channel, do not choose an RF Channel that is currently being used by other JOWA Consilium Wireless Systems as this can cause communication problems.

5.2 RF Baud Rate Selection

The RF Baud Rate refers to the speed at which the Base Radio and Field Units communicate. There are three selectable settings with the quickest update times and longest communication ranges listed below:

- 4.8K — Rate of 4.8 Kbaud (Update every 20 seconds)
— Range of 3000 ft (Line of Sight)
- 19.2K — Rate of 19.2 Kbaud (Update every 5 seconds)
— Range of 2000 ft to 2500 ft (Line of Sight)
- 76.8K — Rate of 76.8 Kbaud (Update every 1 second)
— Range of 500 ft to 750 ft (Line of Sight)

A faster RF Baud Rate will allow you to transmit more information in a certain period of time, but it will also limit your range. If you need more distance out of your Field Units or are encountering difficulties by frequently losing communications, then select a slower baud rate or switch to a high gain antenna.



Note If you change the baud rate of the Base Radio, you must also change the baud rate of all other Field Units that are communicating with that Base Radio.

Follow the Base Radio menu map shown in Figure 5-2 to configure the RF Baud Rate. The factory default is the 19.2K Baud Rate.

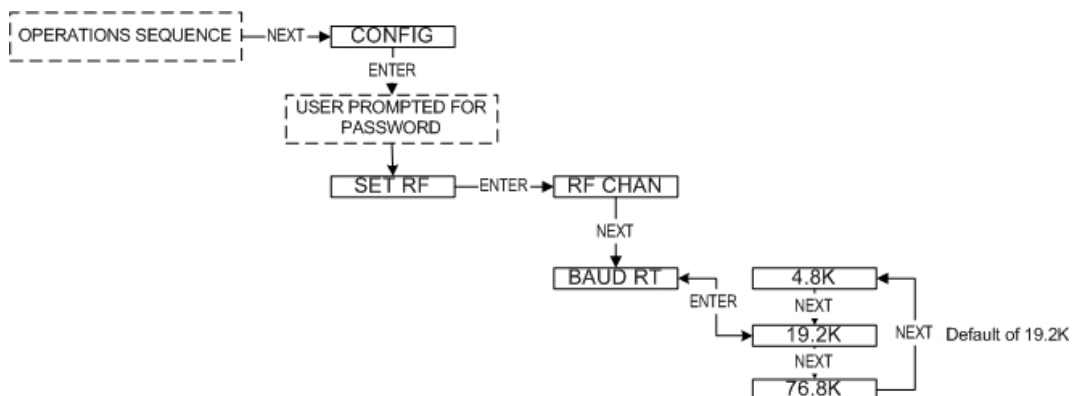

Figure 5-2 Menu Map to RF Baud Rate Setting

5.3 High RF ID Setting

The Number of Wireless Instruments setup allows you to track Field Unit communication. By indicating the number of Field Units allotted to that particular Base Radio, the Base Radio can judge whether or not it is missing communication with a Field Unit and then warn the user.

For example, if you had 10 Field Units to be set to this Base Radio, you would set the number of wireless instruments to 10. When you returned to the operations sequence you would then read “BASE OK” and “10 WI”) if all the Field Units were in communication

with the Base Radio. If one Field Unit was not in communication with the Base Radio, you would read "MIS 1" and "9 WI" for the 1 missing Field Unit.

Follow the Base Radio menu map shown below to configure the number of wireless instruments (Field Units). The factory default is 001. There is a limit of 100 Field Units per Base Radio.



Figure 5-3 High RFID Setting

6 Configuring the Modbus Communications

This section applies only if you have ordered the Modbus communications option for the Base Radio. The Base Radio identification number should read WI-BR-I-XP-MOD. If you have not ordered this option please skip this section. The subsections are as follows:

- 6.1: Base Radio Setup
 - 6.1.1: *Modbus Baud Rate Setting*
 - 6.1.2: *Modbus Device ID Setting*
 - 6.1.3: *Modbus Parity Setting*
 - 6.1.4: *Modbus Mapping Mode Setting*
- 6.2: Modbus Communication Protocol
- 6.3: Modbus Commands
 - 6.3.1: *Command 03-Read Holding Registers*
 - 6.3.1.1: *Base Radio Holding Registers*
 - 6.3.1.1.1: *Base Radio Device Type Holding Registers*
 - 6.3.1.1.2: *Base Radio Device Status Holding Registers*
 - 6.3.1.1.3: *Base Radio On/Offline Field Unit Registers*
 - 6.3.1.2: *Field Unit Holding Registers*
 - 6.3.1.2.1: *Field Unit Device Type Holding Registers*
 - 6.3.1.2.2: *Field Unit Device Status Holding Registers*
 - 6.3.2: *Command 08- Diagnostic*
 - 6.3.3: *Command 11- Get Com Event Counter*
 - 6.3.4: *Command 12- Get Com Event Log*
 - 6.3.5: *Command 17- Report Slave ID*
 - 6.3.6: *Command 43- Read Device ID*
- 6.4: Base Radio Holding Registers
 - 6.4.1: *Base Radio Device Type Registers*
 - 6.4.2: *Base Radio Device Status Registers*
 - 6.4.3: *Base Radio On/Offline Field Unit Registers*
- 6.5: Field Unit Holding Registers
 - 6.5.1: *Device ID Mapping Mode*
 - 6.5.2: *Register Mapping Mode*
 - 6.5.3: *Field Unit Device Type Holding Registers*
 - 6.5.4: *Field Unit Device Status Registers*



Note This device supports Modbus RTU (Binary) communications. Note that the ASC-II transmission mode is not supported.

6.1 Base Radio Setup

The purpose of this section is to guide you through the configuration of the Base Radio in order to enable communications with your particular Modbus Protocol.

6.1.1 Modbus Baud Rate Setting

In order for the Base Radio to communicate with other devices, such as the server computer or an existing PLC/DCS system, they must share the same Modbus Baud Rate.

To set the Modbus Baud Rate, first determine which rate your system requires. If your system will allow any baud rate, we suggest you use the fastest setting; however, some systems cannot handle these faster baud rates due to external noise and transmission distance. If you encounter communication problems between the Base Radio and server computer or existing system, try a slower baud rate setting.

Once you have determined the Modbus Baud Rate you wish to use, follow the Base Radio menu map shown in Figure 6-1 to configure the Baud Rate. The factory default is 19.2 K.

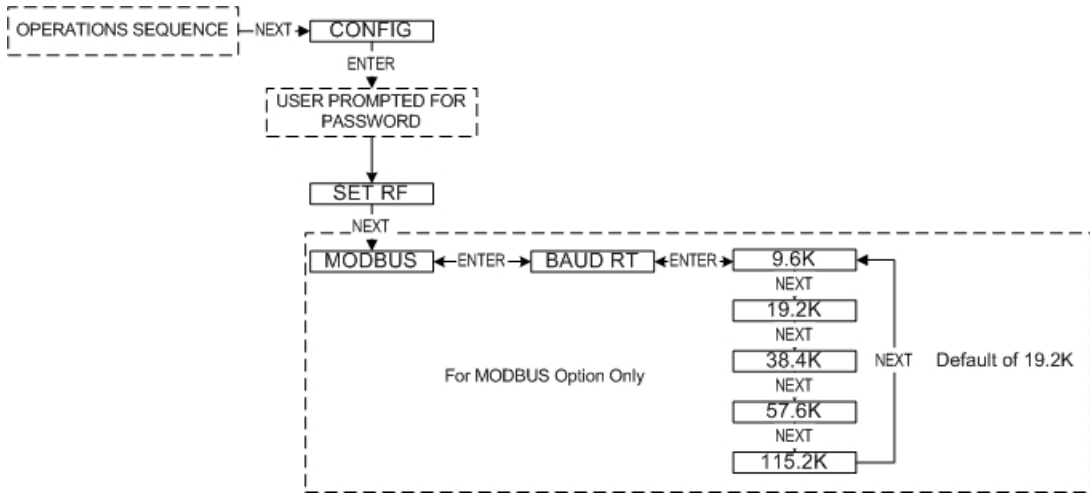

Figure 6-1 Menu Map to Modbus Baud Rate Setting

6.1.2 Modbus Device ID Setting

The Modbus Device ID allows a PLC or DCS to find the proper Base Radio on a RS-485 Network.

Because Modbus needs a device ID for each Field Unit, they have been virtually mapped according to the Base Radio with which they are communicating. The device ID range is dependent on the MODMAP setting in the Base Radio. (See Modbus Mapping Mode section 6.1.4 for more information.)

In the Register Mapping Mode you may select any device ID from 1 to 247. This number will be the device Modbus device ID at which all the readable registers for the Base Radio and every Field Unit will be located. More detail about each register, and its meaning can be found in the Modbus Communications Protocol section.

In the Device ID Mapping Mode you may select any device ID from 1 to 247 minus the number of Field Units communicating with this Base Radio. The change in the device ID ceiling is due to the fact that each Field Unit's device ID is located at its RF ID + the Base Radio device ID. Thus you need the space beyond the Base Radio address to contain all the Field Units' address.

For example: If there are two Base Radios on the Modbus RS-485 network, and each of the two Base Radios are communicating with three Field Units, the device ID scheme would result as follows:

- Base Radio with Modbus device ID 001
 - ⇒ Field Unit with RF ID 1 is found at Modbus device ID 002
 - ⇒ Field Unit with RF ID 2 is found at Modbus device ID 003
 - ⇒ Field Unit with RF ID 3 is found at Modbus device ID 004
- Base Radio with Modbus device ID 101
 - ⇒ Field Unit with RF ID 1 is found at Modbus device ID 102
 - ⇒ Field Unit with RF ID 2 is found at Modbus device ID 103
 - ⇒ Field Unit with RF ID 3 is found at Modbus device ID 104

More detail about the registers at each address, and their meaning, can be found in the Modbus Communications Protocol section.

Once you have determined the Modbus Device ID you wish to use, follow the Base Radio menu map shown in Figure 6-2 to configure the device ID. The factory default is 001:

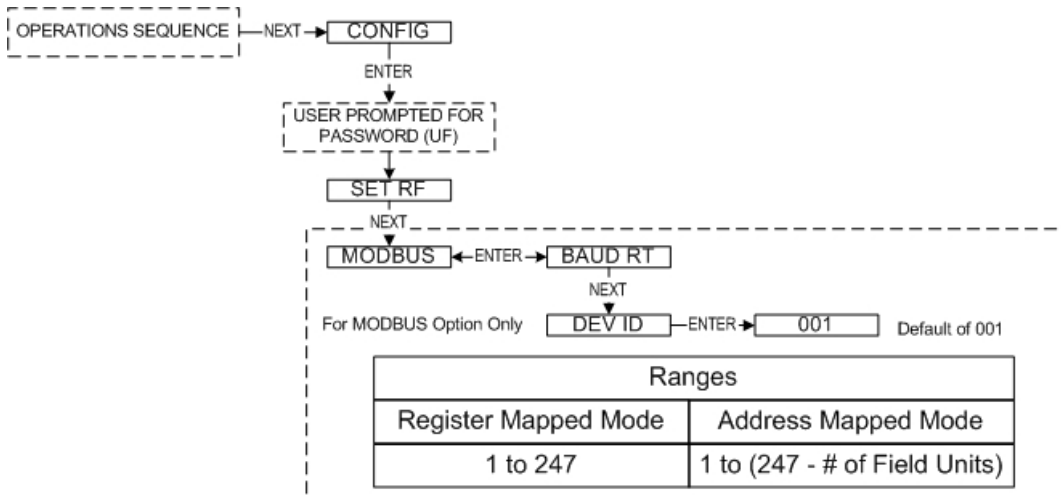

Figure 6-2 Menu Map to Modbus Device ID Setting



Note The Base Radio provides different Device ID modes in order to support a wide range of Modbus equipment.

In the **Register Mapping Mode** the data for the Base Radio and all Field Units are located under a single device ID. This ID may be any allowable Modbus address between 1 and 247 that doesn't conflict with an address of existing device or Modbus network.

In the **Device ID Mapping Mode** each Field Unit is given its own unique ID and registers. The Field Unit ID is equal to the value of the Base Radio ID added to the Field Units RF ID.



Note Make sure that the **HI RF ID** setting has been configured properly or the Modbus addressing scheme could be affected.

To properly set the **HI RF ID** setting see Section 4.2.

6.1.3 Modbus Parity Setting

The Modbus Parity distinguishes which type of parity is used to validate each packet of information on the RS-485 Network. The type of parity required is usually indicated by the user's PLC.

Selecting EVEN or ODD parity will automatically include one STOP bit per frame. Selecting a parity of NONE will automatically include two STOP bits as per the Modbus communications specification.

Follow the Base Radio menu map shown in Figure 6-3 to configure the parity. The factory default is EVEN parity.

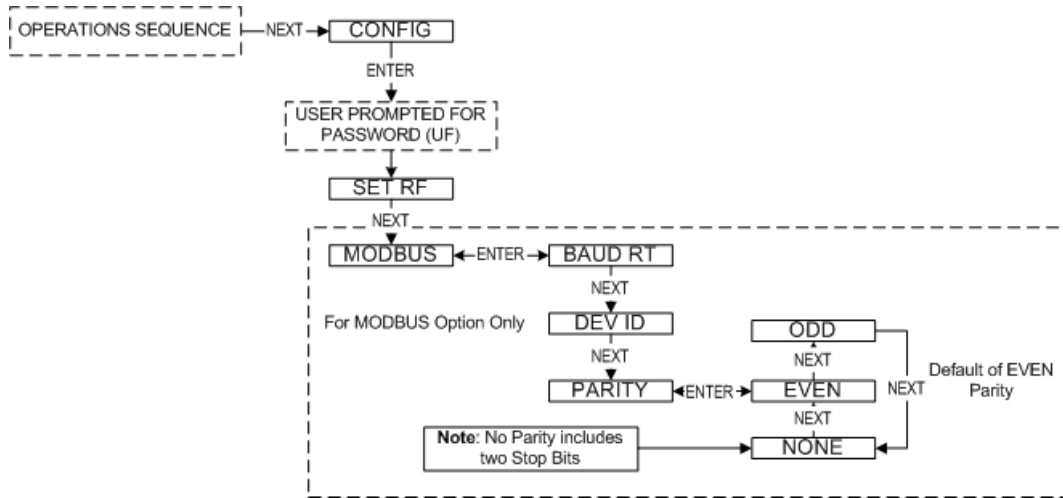

Figure 6-3 Menu Map to Modbus Parity Setting

6.1.4 Modbus Mapping Mode Setting

The Modbus Mapping mode distinguishes which type of mapping mode is used to map the Modbus registers according to the device IDs.



Note Make sure that the **HI RF ID** setting has been configured properly or the Modbus addressing scheme could be affected. To properly set the **HI RF ID** setting see Section 4.2.

There are two possible mapping modes that can be used. The first is the Device ID mapping mode. Using this mode gives the Base Radio a device ID equal to its device ID setting. There are then 10 Modbus registers located at this device ID for this Base Radio. Each Field Unit communicating with this Base Radio is then located at device ID X, where X is the RF ID of the Field Unit + the Device ID of the Base Radio. There are 10 Modbus registers for each Field Unit located at that Unit's device ID. For more information on the registers, see Section 6.2: Modbus Communications Protocol.

The other possible mapping mode that can be used is the Register Mapping mode. Using this mode gives the Base Radio a device ID equal to its device ID setting. Then, the 10 Base Radio Modbus registers are registers 1 – 10, and the Field Unit with RF ID 1 is located at the SAME device ID as the Base Radio but its registers are registers 11-20. Each subsequent Field Unit is mapped similarly. For more information on the registers, Section 6.2: Modbus Communications Protocol.

Follow the Base Radio menu map, shown in Figure 6-4, to configure the mapping mode. The factory default is the Device ID mode.

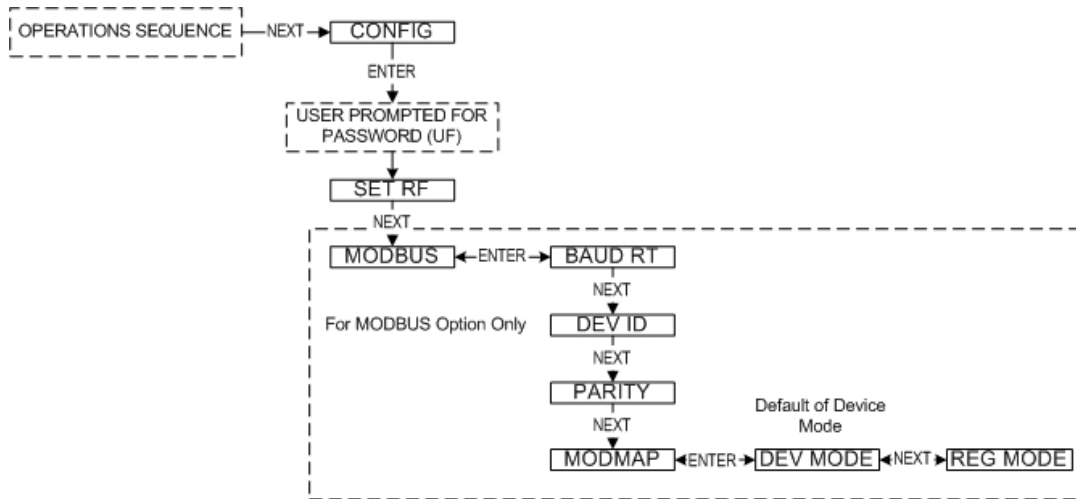

Figure 6-4 Menu Map to Modbus Mapping Mode Setting

6.2 Modbus Communication Protocol

The Base Radio connects to the Host (Master) system using Modbus over a serial RS-485 line. The Base Radio supports Modbus RTU transmission mode at baud rates of 9600, 19200, 38400, 57600, or 115200 baud with even, odd, or no parity and 8 data bits. One stop bit is used if even or odd parity is selected and two stop bits are used if the no parity option is selected to fill out the character frame to a full 11-bit character. Unless modified by the user, default values of 19200 baud, 8 data bits, even parity, and one stop bit are used.



Note This device supports Modbus RTU (Binary) communications. Note that the ASC-II transmission mode is not supported.

The Base Radio is always located at the device ID selected by the **DEV ID** menu item. Field units can be configured either to be assigned to an individual Modbus device ID or to holding registers within the Base Radio device ID through the appropriate selection in the **MODMAP** menu item. There are two **MODMAP** modes available: **DEVMODE** and **REGMODE**.

If the device ID mode (**DEVMODE**) is selected, a Field Unit's data may be accessed with the Modbus Read Holding Register Command (03) by using the Field Unit's equivalent Modbus device ID. The Field Unit's equivalent Modbus device ID is the Base Radio's device ID + the Field Unit's RF ID. For example, if the Base Radio's device ID was 10 and a Field Unit's RF ID was 5, the Field Unit would be accessed under Modbus device ID 15. Using the device ID mapping mode adjusts the upper limit of the Base Radio's device ID to 247 minus the number of Field Units on the RF network. For example, if 5 Field Units were on the Base Radio's network, the maximum Modbus device ID would be 242.

If the register-mapping mode (**REGMODE**) is selected, a Field Unit's data may be accessed with the Modbus Read Holding Register command (03) using the Base Radio's

device ID. The Base Radio uses register addresses 1 through 10 with each subsequent group of 10 registers used by a Field Unit.

The RF online/offline status of a Field Unit can be determined through a number of different sources. In the Base Radio holding registers, a count of the current number of online Field Units can be found at address 00004. Also the individual online/offline status of each Field Unit is stored in the Base Radio holding registers at addresses 00005, 00006, 00007, and 00008. These registers are bit field variables with each bit of the 16-bit number representing the status of a Field Unit. If the bit is set, the corresponding Field Unit is online. If the bit is cleared, the corresponding Field Unit is offline.

In the Field Unit holding registers, bit 1 in the Field Unit & Sensor Status holding register holds the online/offline status of the particular device. Any Field Unit that is currently offline will return NaN (Not a Number) when queried for its primary or secondary measurement value. Note that if a Field Unit is online and is a single measurement device type, NaN will also be returned for the Secondary Sensor Value, as the measurement does not exist in these devices.

6.3 Modbus Commands

The Base Radio responds to six Modbus commands including the Read Holding Registers (03), Diagnostic (08), Get Com Event Count (11), Get Com Event Log (12), Report Slave ID (17), and Read Device Identification (43). The Read Holding Registers command provides the bulk of the functionality with the remaining commands being used for diagnostics/troubleshooting purposes. No other Modbus commands are supported and will be responded to with an ILLEGAL FUNCTION exception (code 01). A description of each command code is listed in the following sections.

6.3.1 Command 03-Read Holding Registers

This command is used to read the contents of a contiguous block of holding registers in a Base Radio or Field Unit. If an invalid register address is requested, an ILLEGAL DATA ADDRESS exception (code 02) will be returned.

Section 6.4 lists the holding registers for the Base Radio and Field Units, as well as how to understand the contents of the registers.

6.3.2 Command 08- Diagnostic

This command provides a number of tests for checking the communications between the Base Radio and the Host master device.

Subfunction Code	Field Unit Device Status
0	Return Query Data
1	Restart Communications Option
2	Return Diagnostics Register
3	Change ASC-II Input Delimiter (NOT SUPPORTED)
4	Force Listen Only Mode
5-9	NOT USED
10	Clear Counters & Diagnostics Register
11	Return Bus Message Count
12	Return Bus Communication Error Count

Subfunction Code	Field Unit Device Status
13	Return Bus Exception Error Count
14	Return Slave Message Count
15	Return Slave No Response Count
16	Return Slave NAK Count
17	Return Slave Busy Count
18	Return Bus Character Overrun Count
19+	NOT USED

Note that identical information is returned for any device ID that the Base Radio has control of (i.e. including Field Units mapped to virtual device IDs when operating in the device ID mapping mode (See Section 6.2).

6.3.3 Command 11- Get Com Event Counter

This command returns a two-byte status word and the device's event counter. The status word will either be 0 or 65535 if the previous command is still being processed. The event counter is incremented for each successful message received. The counter is not incremented for commands that return exception responses or commands that fetch event counters. The event counter will eventually roll over to 0 after reaching a count of 65535. Note that identical information is returned for any device ID that the Base Radio has control of (i.e. including Field Units mapped to virtual device IDs when operating in the device ID mapping mode).

For further details on this command, please consult the Modbus protocol specification.

6.3.4 Command 12- Get Com Event Log

This command returns a status word, communications event counter, message count, and a field of bytes from the communications event log. The status word and communications event counter are identical to those returned by Command 11 (Get Com Event Counter) above. The message count is a count of the total number of messages received by this device, including messages intended specifically for this device as well as other devices on the Modbus network. The event log keeps track of information on the last 7 communications events. Note that identical information is returned for any device ID that the Base Radio is controlling (including Field Units mapped to virtual device IDs when operating in the device ID mapping mode).

For further details on this command, please consult the Modbus protocol specification.

6.3.5 Command 17- Report Slave ID

This command returns the device type, device status, and a run indicator status byte. The 16-bit device type and device status words are identical to those held in the holding registers. The run indicator status byte is 255 (0xFF hex) if the device is online and 0 (0x00 hex) if the device is offline. Unlike some of the other diagnostics commands, different information is returned depending on whether the device ID used in this command corresponds to the Base Radio or one of the Field Units mapped to a device ID when operating in the device ID mapping mode.

For further details on this command, please consult the Modbus protocol specification.

6.3.6 Command 43- Read Device ID

This command returns identification information relating to the device. The conformity level of this command is level 01, basic identification (stream access only). As with most of the other diagnostic commands, identical information is returned for any device ID that the Base Radio is controlling (including Field Units mapped to virtual device IDs when operating in the device ID mapping mode).

For further details on this command, please consult the Modbus protocol specification.

6.4 Base Radio Holding Registers

The following are the Base Radio holding registers for all mapping modes (i.e. Device ID and Register mapping modes). The values for each address are listed later in this section.



Note Use this table for RF IDs 1 through 50 and for backwards compatibility.

Base Radio Holding Register (All Mapping Modes)	Device ID: 1 To 247 Max.	
Register Address	Description	Register Type
00001	Device Type	16-Bit Unsigned Int
00002	Device Status	16-Bit Unsigned Int
00003	Number of Field Units Expected	16-Bit Unsigned Int
00004	Number of Field Units Communicating	16-Bit Unsigned Int
00005	Online/Offline Status Of Field Units 1-16	16-Bit Unsigned Intf
00006	Online/Offline Status Of Field Units 17-32	16-Bit Unsigned Int
00007	Online/Offline Status Of Field Units 33-48	16-Bit Unsigned Int
00008	Online/Offline Status Of Field Units 49-50	16-Bit Unsigned Int
00009	Diagnostic Counter	16-Bit Unsigned Int
00010	Reserved For Future Use	16-Bit Unsigned Int



Note Use the table below if more than 50 are being used (RF IDs 51 through 100).

Register Address	Description
10001	Base Radio Device Type (Mirrored from the existing value at address 00001.)
10002	Base Radio Status (Mirrored from existing value at address 00002.)
10003	Number of Expected Field Units on this Network (Mirrored from existing value at address 00003.)
10004	Number of Field Units that are Actually Online (Mirrored from existing value at address 00004.)
10005	Online/Offline Status of Field Units with RF IDs 1-16 (Mirrored from existing value at address 00005.)
10006	Online/Offline Status of Field Units with RF IDs 17-32 (Mirrored from existing value at address 00006.)

10007	Online/Offline Status of Field Units with RF IDs 33-48 (Mirrored from existing value at address 00007.)
10008	Online/Offline Status of Field Units with RF IDs 65-80 (New information.)
10009	Online/Offline Status of Field Units with RF IDs 65-80 (New information.)
10010	Online/Offline Status of Field Units with RF IDs 81-96 (New information.)
10011	Online/Offline Status of Field Units with RF IDs 97-100 (New information.)

6.4.1 Base Radio Device Type Registers

The Base Radio Device Type value is 255. This is the only possible value for the Device Type holding registers for a Base Radio. Note that the register is a 16-bit unsigned int for Base Radios.

6.4.2 Base Radio Device Status Registers

The following are the values for the Device Status holding registers. These registers are bit field registers represented as a 16-bit unsigned int for Base Radios.

Value	Base Radio Device Status
1	Base Radio Online
2+	Reserved For Future Use

6.4.3 Base Radio On/Offline Field Unit Registers

Below are the values for the Online/Offline Status of Field Units 1-16 holding register in the Base Radio. The other online/offline status holding registers hold the status of the remaining Field Units with RF IDs 17 through 50.

Value	Field Unit Device Status
1	Field Unit 1 Online Status
2	Field Unit 2 Online Status
4	Field Unit 3 Online Status
8	Field Unit 4 Online Status
16	Field Unit 5 Online Status
32	Field Unit 6 Online Status
64	Field Unit 7 Online Status
128	Field Unit 8 Online Status
256	Field Unit 9 Online Status
512	Field Unit 10 Online Status
1024	Field Unit 11 Online Status
2048	Field Unit 12 Online Status
4096	Field Unit 13 Online Status
8192	Field Unit 14 Online Status
16384	Field Unit 15 Online Status
32768	Field Unit 16 Online Status

To decode the status register, take the value of the register and subtract the largest value listed in the table above that does not cause the result to be negative. Take the resulting

total from the subtraction and subtract the next largest number possible and so on until the result is zero. Each value that was used in the subtraction indicates that the Field Unit is online.

For example: The On/Offline Status holding register contains the value 15. In this case the largest value we can subtract is 8, which leaves a result of 7. Now we can subtract 4 from 7 and get 3. Now subtract 2 from 3 and we get 1. Finally we subtract 1 from 1 and get 0, so we are done. Which Field Units are online? We subtracted 8,4,2 and 1, and these numbers correspond to Field Units' with RF IDs 1,2,3 and 4.



Note An alternate method to determining which Field Unit(s) are online is to look at the Base Radio Holding Register as a binary number with the rightmost bit representing Field Unit 1 and the leftmost bit representing Field Unit 16. For example, the binary representation for Field Units 1-4 online is as follows:

0000000000001111

In another example, say the On/Offline Status holding register contains the value 6. We can subtract 4 to get 2. Then we can subtract 2 to get 0. Thus Field Unit 2 and 3 are online, but Field Units 1 and 4 are offline.

6.5 Field Unit Holding Registers

The following are the Field Unit holding registers when used in the **Device ID Mapping Mode** (First Table) and the **Register Mapping Mode** (Second Table).

6.5.1 Device ID Mapping Mode

Field Unit Holding Registers (DEVMODE Only)	Device ID = Base Radio Modbus ID + RF ID	
Register Address	Description	Register Type
00001	Device Type	32-Bit IEEE
00002	Device Type	Floating Point
00003	Device Status	32-Bit IEEE
00004	Device Status	Floating Point
00005	Primary Sensor Value	32-Bit IEEE
00006	Primary Sensor Value	Floating Point
00007	Secondary Sensor Value	32-Bit IEEE
00008	Secondary Sensor Value	Floating Point
00009	Tertiary Sensor Value	32-Bit IEEE
00010	Tertiary Sensor Value	Floating Point

6.5.2 Register Mapping Mode

Field Unit Holding Registers (REGMODE Only)	Device ID = Base Radio Modbus ID	
Register Address	Description	Register Type
00001 + (RF ID * 10)	Device Type	32-Bit IEEE
00002 + (RF ID * 10)	Device Type	Floating Point
00003 + (RF ID * 10)	Device Status	32-Bit IEEE
00004 + (RF ID * 10)	Device Status	Floating Point
00005 + (RF ID * 10)	Primary Sensor Value	32-Bit IEEE
00006 + (RF ID * 10)	Primary Sensor Value	Floating Point

00007 + (RF ID * 10)	Secondary Sensor Value	32-Bit IEEE
00008 + (RF ID * 10)	Secondary Sensor Value	Floating Point
00009 + (RF ID * 10)	Tertiary Sensor Value	32-Bit IEEE
00010 + (RF ID * 10)	Tertiary Sensor Value	Floating Point



Note If you have purchased any Wireless **Differential Pressure Field Units**, please see the User Guide for specific Modbus holding register differences from those listed in the following sections.

6.5.3 Field Unit Device Type Holding Registers

The following are possible values for the Device Type holding registers. Note that the register is a 32-bit floating point value for Field Units.

Value	Device Type
0	Acoustic Monitor Field Unit
1	RTD Field Unit
2	Pressure Field Unit
3	Dual 0-10V Input Field Unit
4	Dual 4-20mA Input Field Unit
5	Thermocouple Field Unit
6	Reserved
7	Level Sensor Field Unit
8	Split RTD Field Unit
9	Split Pressure Field Unit
10	Split Dual Thermocouple Field Unit
11	Differential Pressure Field Unit (100 IN. H2O)
12	Split Differential Pressure Field Unit (100 IN. H2O)
13	Differential Pressure Field Unit (300 IN. H2O)
14	Split Differential Pressure Field Unit (300 IN. H2O)
15	Differential Pressure Field Unit (25 PSID)
16	Split Differential Pressure Field Unit (25 PSID)
17	Differential Pressure Field Unit (100 PSID)
18	Split Differential Pressure Field Unit (100 PSID)
19	Differential Pressure Field Unit (300 PSID)
20	Split Differential Pressure Field Unit (300 PSID)
21	Reserved
22	Reserved
23	Gauge and Submersible Level Field Units
24	Split Gauge and Submersible Level Field Units
25	Advanced Development
26	Switch Input Field Unit
27	Switch Input Field Unit with Output Options

6.5.4 Field Unit Device Status Registers

The following are the values for the Device Status holding registers. These registers are bit field registers represented as a 32-bit floating point values for Field Units.

Value	Field Unit Device Status
1	Field Unit Online
2	Low Battery Condition
▶ 4	Alarm Condition (WI-AM only)
8	Sensor Error Condition
16	Sensor Overrange Condition
32	System Error Condition
64	Switch Input 1 Closed
128	Switch Input 2 Closed
▶ 256	Sq. Root Funct. (WI-DP only - see below)

Again, like Section 6.4.3, the status can be resolved by subtracting the largest number listed above from the value received from the holding register, and then subtracting the next highest and so on until the result is 0. Each of the values used indicate the respective condition listed above.

For example, the holding register reads 9, then subtract 8 and get 1. Then subtract 1 from 1 and get 0. Thus from the list above, we have a Sensor Error Condition and the Field Unit is online.

7 Technical Specifications

Power Characteristics

- 10VDC-30VDC, 24 VDC @ 200mA typical

RF Characteristics

- 902 MHz – 928 MHz Frequency Hopping Spread Spectrum (FHSS), FCC certified ISM license-free band
- Up to 3000' range to field units with clear line of sight; 500' to 1000' range with obstructions
- The RF module in each field unit is individually tested and calibrated over the full temperature range to ensure reliable wireless operation

Output Options

- RS-485 digital communications (WBR-I-XP) with conversion to RS-232 or USB for interface with PC or server and WIM (WIM) (optional)
- Serial Modbus RTU (Binary) (WBR-I-XP-MOD) over RS-485
- Modbus over TCP/IP (via optional converter)

Physical Characteristic

- Baked enamel explosion-proof, weather-proof and corrosion-proof housing
- Electromagnetic Compatibility
- (CE Compliance)
- Operates within specification in fields from 80 to 1,000 MHz with field strengths to 30 V/m. Meets EN 50082-1 general immunity standard and EN 55011 compatibility emissions standard

Industrial Certification

- Rated for industrial use FM rated: -40°F to 185°F(-40°C to 85°C) CSA Rated: -40°F to 104°F(-40°C to 40°C)
- FM Approved as explosion-proof (XP) for Class I, Division 1, Groups B,C,&D, T6; as dust ignition-proof for Class II/III, Division 1, Groups E, F, &G, T6; indoor and outdoor (Type 4X) hazardous (classified) locations.
- CSA Approved as explosion-proof (XP) for Class I, Division 1, Groups B,C,&D, T6; as dust ignition-proof for Class II/III, Division 1, Groups E, F, &G, T6; indoor and outdoor (Type 4X) hazardous (classified) locations.
- NEMA 4X explosion-proof housing

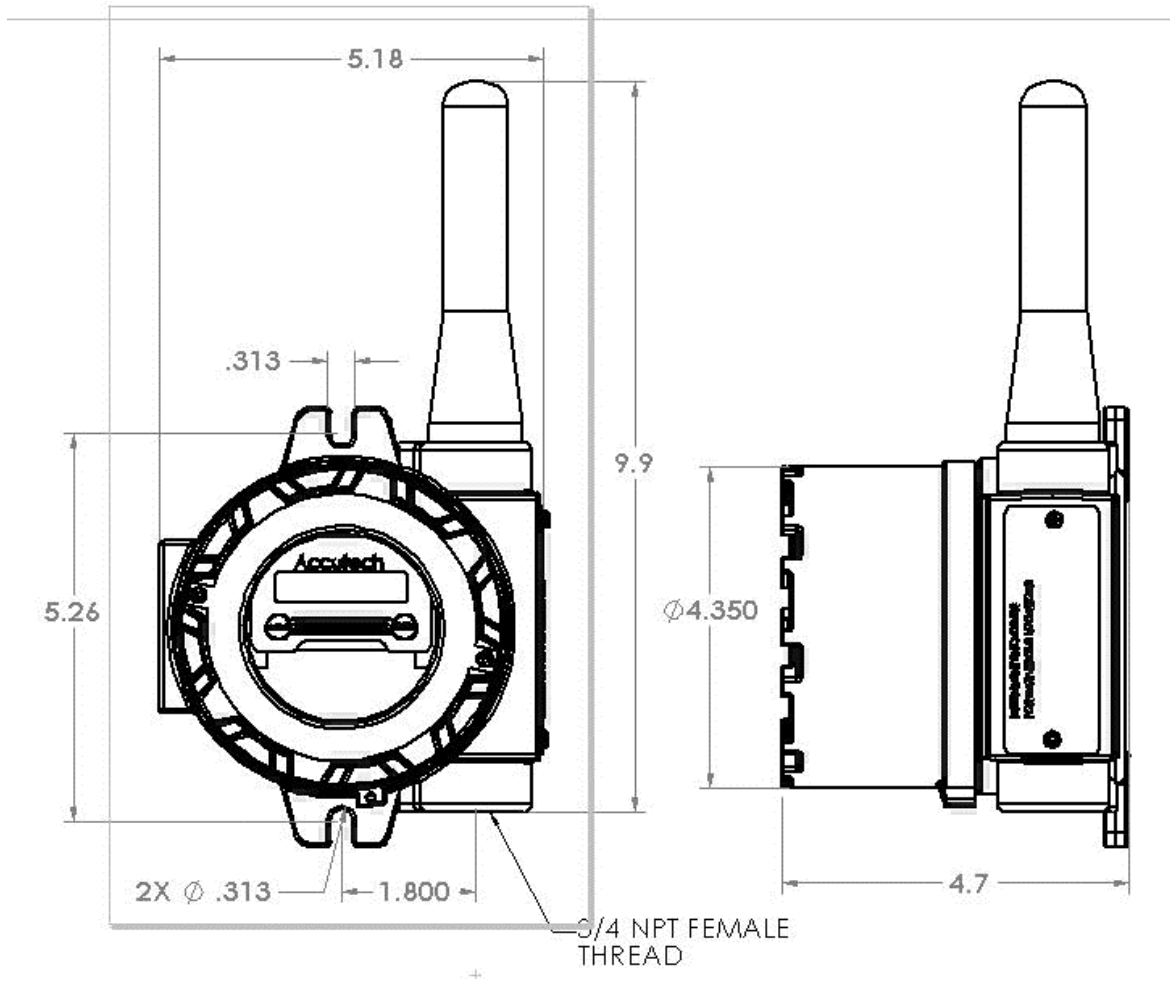

Figure 7-1 Overall Base Radio Dimensions

Appendix A Navigating the Menus

Pressing either the NEXT or ENTER buttons located on the front of the Field Unit or Base Radio just below the Liquid Crystal Display (LCD) screen is all that is needed to navigate the respective menus. Pressing both of these buttons for one second will turn the unit on.

Pressing the NEXT button at any time while the Base Radio is cycling through the normal messages causes the Base Radio to enter the setup mode. The NEXT button is then used to step through menu options, and the ENTER button is used to enter a submenu of what is displayed on the LCD at that time. If no button is pressed within a 30 second period the unit goes back to the normal display mode.

If you enter a submenu that requires a numerical input, such as 001, the leftmost 0 will be blinking. This indicates that pressing the NEXT button will increment this value with each press from 0 to 9 and back to 0 again. Pressing the ENTER button will move to the next available value. If the last value is blinking, pressing ENTER will save the entered values and return to the return from the sub menu.

Appendix B Base Radio Menu Map

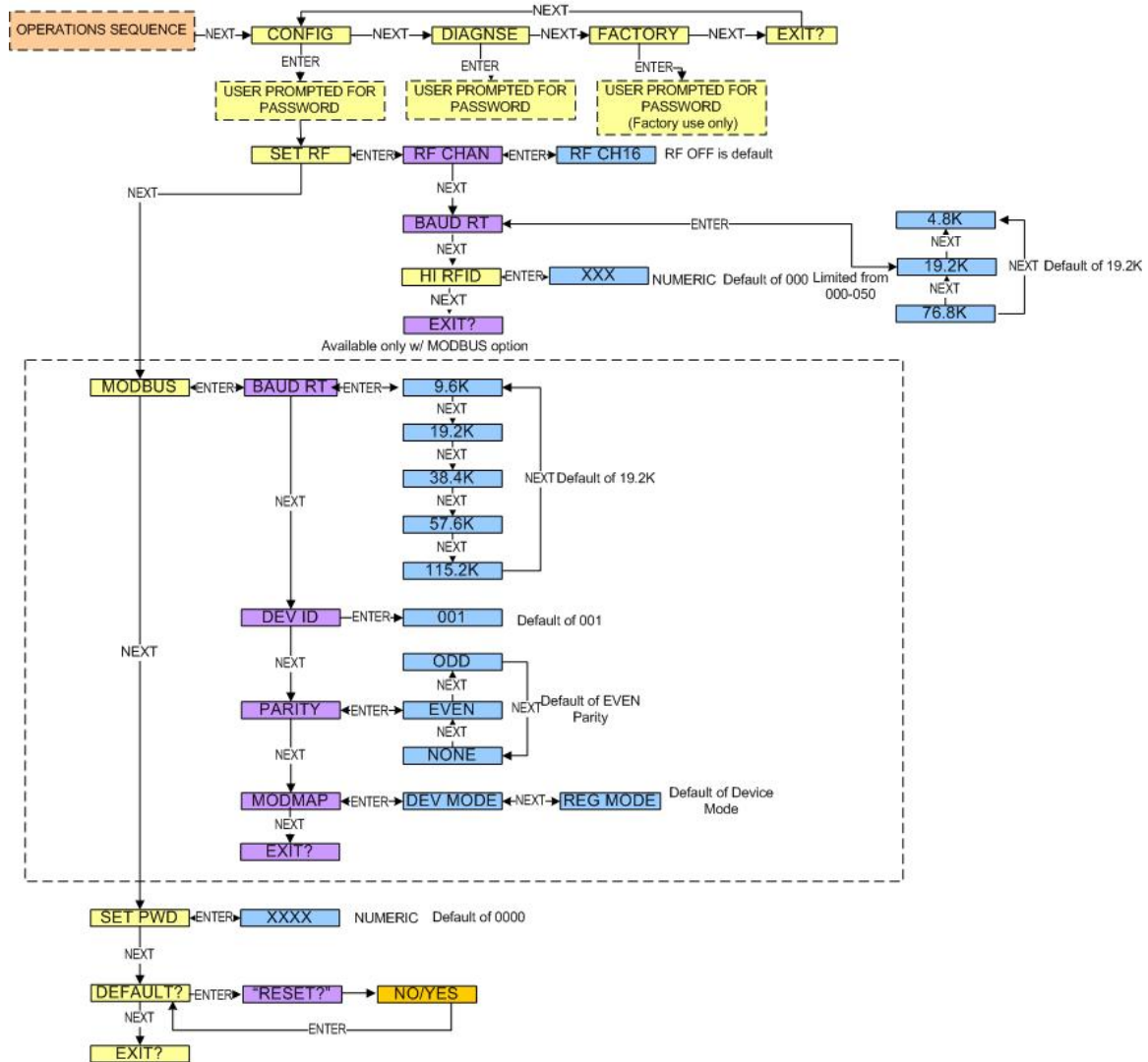

Figure A- 1 Base Radio Menu Map

Appendix C Modbus Register Definitions

/ Temperature Units */*

DegC = 32, */* Degrees Celcius */*
DegF = 33, */* Degrees Fahrenheit */*
DegR = 34, */* Degrees Rankine */*
DegK = 35, */* Kelvin */*

/ Pressure Units */*

InH2OAt68F = 1, */* inches of water at 68 degF */*
InHgAt0C = 2, */* inches of mercury at 0 degC */*
FtH2OAt68F = 3, */* feet of water at 68 degF */*
MMH2OAt68F = 4, */* millimeters of water at 68 degF */*
MMHgAt0C = 5, */* millimeters of mercury at 0 degF */*
PSI = 6, */* pounds per square inch */*
BAR = 7, */* bars */*
MilliBAR = 8, */* millibars */*
GMPerSqCm = 9, */* grams per square centimeter */*
KGPerSqCm = 10, */* kilograms per square centimeter */*
Pascals = 11, */* pascals */*
KiloPascals = 12, */* kilopascals */*
Torr = 13, */* torrcellis */*
Atmospheres = 14, */* atmospheres */*
InH2OAt60F = 145, */* inches of water at 60 degF */*
CmH2OAt4C = 170, */* centimeters of water at 4 degC */*
MetH2OAt4C = 171, */* meters of water at 4 degC */*
CmHgAt0C = 172, */* centimeters of mercury at 0 degC */*
PSF = 173, */* pounds per square foot */*
HectoPascals = 174, */* hectopascals */*
PSIA = 175, */* pounds per square inch absolute */*
KGPerSqMeter = 176, */* kilograms per square meter */*
FtH2OAt4C = 177, */* feet of water at 4 degC */*
FtH2OAt60F = 178, */* feet of water at 60 degF */*
MetHgAt0C = 179, */* meters of mercury at 0 degC */*
MegaPascals = 237, */* megapascals */*
InH2OAt4C = 238, */* inches of water at 4 degC */*
MMH2OAt4C = 239, */* millimeters of water at 4 degC */*

/ Volumetric Flow Units */*

CuFtPerMin = 15, */* cubic feet per minute */*
GalPerMin = 16, */* gallons per minute */*
LiterPerMin = 17, */* liters per minute */*
ImpGalPerMin = 18, */* imperial gallons per minute */*
CuMeterPerHr = 19, */* cubic meter per hour */*
GalPerSec = 22, */* gallons per second */*
MillionGalPerDay = 23, */* million gallons per day */*
LiterPerSec = 24, */* liters per second */*
MillionLiterPerDay = 25, */* million liters per day */*
CuFeetPerSec = 26, */* cubic feet per second */*
CuFeetPerDay = 27, */* cubic feet per day */*
CuMeterPerSec = 28, */* cubic meters per second */*
CuMeterPerDay = 29, */* cubic meters per day */*
ImpGalPerHr = 30, */* imperial gallons per hour */*
ImpGalPerDay = 31, */* imperial gallons per day */*
NormCuMeterPerHr = 121, */* normal cubic meter per hour - MKS System */*
NormLiterPerHr = 122, */* normal liter per hour - MKS System */*
StdCuFtPerMin = 123, */* standard cubic feet per minute - US System */*
CuFeetPerHour = 130, */* cubic feet per hour */*
CuMeterPerMin = 131, */* cubic meters per minute */*
BarrelPerSec = 132, */* barrels per second - 1 Barrel = 42 US gallons */*
BarrelPerMin = 133, */* barrels per minute */*
BarrelPerHr = 134, */* barrels per hour */*
BarrelPerDay = 135, */* barrels per day */*
GalPerHr = 136, */* gallons per hour */*
ImpGalPerSec = 137, */* imperial gallons per hour */*
LiterPerHr = 138, */* liters per hour */*

```

/* Velocity Units */
FtPerSec = 20, /* feet per second */
MetersPerSec = 21, /* meters per second */
InPerSec = 114, /* inches per second */
InPerMin = 115, /* inches per minute */
FtPerMin = 116, /* feet per minute */
MetersPerHr = 120, /* meters per hour */

/* Volume Units */
Gallons = 40, /* gallons */
Liters = 41, /* liters */
ImpGallons = 42, /* imperial gallons */
CuMeters = 43, /* cubic meters */
Barrels = 46, /* barrels */
Bushels = 110, /* bushels */
CuYard = 111, /* cubic yards */
CuFeet = 112, /* cubic feet */
CuInch = 113, /* cubic inches */
BarrelsLiquid = 124, /* liquid barrels - 1 bbl liq = 31.5 US gallons */
NormalCuMeter = 166, /* normal cubic meter - MKS System */
NormalLiter = 167, /* normal liter - MKS System */
StdCuFeet = 168, /* standard cubic feet - US System */
HectoLiter = 236, /* hectoliters */

/* Length Units */
Feet = 44, /* feet */
Meters = 45, /* meters */
Inches = 47, /* inches */
CM = 48, /* centimeters */
MM = 49, /* millimeters */
FtInSixteenths = 151, /* see Note 1 in HART document HCF_SPEC-183 */
/* Time Units */
Min = 50, /* minutes */
Sec = 51, /* seconds */
Hr = 52, /* hours */
Day = 53, /* days */

/* Mass Units */
Gram = 60, /* grams */
KG = 61, /* kilograms */
MetricTon = 62, /* metric tons */
Pound = 63, /* pounds */
ShortTon = 64, /* short tons */
LongTon = 65, /* long tons */
Ounce = 125, /* ounce */

/* Mass Flow Units */
GramPerSec = 70, /* grams per second */
GramPerMin = 71, /* grams per minute */
GramPerHr = 72, /* grams per hour */
KGPerSec = 73, /* kilograms per second */
KGPerMin = 74, /* kilograms per minute */
KGPerHr = 75, /* kilograms per hour */
KGPerDay = 76, /* kilograms per day */
MetTonPerMin = 77, /* metric tons per minute */
MetTonPerHr = 78, /* metric tons per hour */
MetTonPerDay = 79, /* metric tons per day */
PoundsPerSec = 80, /* pounds per second */
PoundsPerMin = 81, /* pounds per minute */
PoundsPerHr = 82, /* pounds per hour */
PoundsPerDay = 83, /* pounds per day */
ShTonPerMin = 84, /* short tons per minute */
ShTonPerHr = 85, /* short tons per hour */
ShTonPerDay = 86, /* short tons per day */
LongTonPerHr = 87, /* long tons per hour */
LongTonPerDay = 88, /* long tons per day */

/* Density Units */
SGU = 90, /* specific gravity units */
GramPerCuCm = 91, /* grams per cubic centimeter */

```

KGPerCuMeter = 92, /* kilograms per cubic meter */
PoundsPerGal = 93, /* pounds per gallon */
PoundsPerCuFt = 94, /* pounds per cubic foot */
GramsPerML = 95, /* grams per milliliter */
KGPerLiter = 96, /* kilograms per liter */
GramsPerLiter = 97, /* grams per liter */
PoundsPerCuIn = 98, /* pounds per cubic inch */
ShTonPerCuYard = 99, /* short tons per cubic yard */
DegTwad = 100, /* degrees twaddell */
DegBaumHeavy = 102, /* degrees baume heavy */
DegBaumLight = 103, /* degrees baume light */
DegAPI = 104, /* degrees API */
MicroGMPerLiter = 146, /* micrograms per liter */
MicroGMPerCuMeter = 147, /* micrograms per cubic meter */
PercentConsistency = 148, /* percent consistency */

/ Viscosity Units */*

Centistokes = 54, /* centistokes */
Centipoise = 55, /* centipoise */

/ Angular Velocity Units */*

DegPerSec = 117, /* degrees per second */
RPS = 118, /* revolutions per second */
RPM = 119, /* revolutions per minute */

/ Energy (Work) Units */*

NM = 69, /* newton meter */
DekaTherm = 89, /* deka therm */
FtLbForce = 126, /* foot pound force */
KWHr = 128, /* kilo watt hour */
MCal = 162, /* mega calorie */
MJ = 164, /* mega joule */
BTU = 165, /* british thermal unit */

/ Force Units */*

Newton = 68, /* newton */

/ Power Units */*

KW = 127, /* kilo watt */
HP = 129, /* horsepower */
MCalPerHr = 140, /* mega calorie per hour */
MJPerHr = 141, /* mega joule per hour */
BTUPerHr = 142, /* british thermal unit per hour */

/ Frequency Units */*

Hertz = 38, /* hertz */

/ Analytical Units */*

Percent = 57, /* percent */
PH = 59, /* pH */
PerSteamQuality = 150, /* percent steam quality */
PercentPlato = 160, /* percent plato */
PerLowExpLevel = 161, /* percent lower explosion level */

/ Capacitance Units */*

PF = 153, /* picofarads */

/ EMF Units */*

MilliVolts = 36, /* millivolts */
Volts = 58, /* volts */

/ Current Units */*

MA = 39, /* milliamperes */

/ Resistance Units */*

Ohms = 37, /* ohms */
KOhms = 163, /* kilo ohms */

/ Angle Units */*

Deg = 143, */* degrees */*

Rad = 144, */* radians */*

/ Conductance Units */*

MicroSiemens = 56, */* micro siemens */*

MilliSiemensPerCM = 66, */* milli siemens per centimeter */*

MicroSiemensPerCM = 67, */* micro siemens per centimeter */*

/ Volume per Volume Units */*

VolumePercent = 149, */* volume percent */*

MilliLitersPerLiter = 154, */* milli liters per liter */*

MicroLitersPerLiter = 155, */* micro liters per liter */*

/ Volume per Mass Units */*

DegBalling = 107, */* degrees balling */*

CuFtPerLb = 152, */* cubic feet per pound */*

/ Concentration Units */*

DegBrix = 101, */* degrees brix */*

PerSolidsPerWt = 105, */* percent solids per weight */*

PerSolidsPerVol = 106, */* percent solids per volume */*

PfPerVol = 108, */* proof per volume */*

PfPerMass = 109, */* proof per mass */*

PPM = 139, */* parts per million */*

PPB = 169, */* parts per billion */*

/ Special Units */*

SpecialUnits = 253

