

**Petrotape / Chemtape
Level Gauging System**

User's Manual

M332I

September 23, 2009

JOWA USA

JOWA USA, Inc.
59 Porter Road
Littleton, MA 01460 USA

Telephone: 978-486-9800
Fax: 978-486-0170

Preface

This manual sets forth the principles, properties, and methods of using the Petrotape and Chemtape Gauging Systems. We believe that you will find your system to be a good solution to your petroleum or chemical gauging requirements. If you need further information or application assistance, please contact the JOWA USA factory or your local JOWA USA representative.

This manual is written primarily for systems that utilize the T-800 series current transmitter. If you have chosen to use the Wireless option, WRT & WBR, please refer to those separate manuals when this manual mentions the T-800.

Conventions and Safety Concerns

This manual uses the following symbols to indicate special considerations in the text.

WARNING

WARNING statements indicate either a personnel or severe equipment hazard. This calls attention to an operating procedure or practice which, if not done correctly or adhered to, could result in possible harm or injury to personnel or damage to the product. Do not proceed beyond a WARNING statement until the conditions are fully understood and met.

Caution

CAUTION statements indicate an equipment hazard. This calls attention to an operating procedure or practice which, if not done correctly or adhered to, could result in damage to the product. Do not proceed beyond a CAUTION statement until the conditions are fully understood and met.

Note

Notes are used to call attention to additional information, to further clarify or emphasize information.

Energy Barrier in Hazardous Area

It is your responsibility to judge the requirements for safety protection. If specifically requested, JOWA USA, Inc. will assist you in designing a system that meets all pertinent requirements for electrical safety in the presence of explosion hazards.

Approved JOWA USA assemblies are available for Petrotape and Chemtape systems which use zener barrier isolators to limit the energy that can pass from the non-hazardous area into leadwires, sensors, indicating meters and current transmitters located in the hazardous area. These units are comprised of discrete barriers for each active signal lead.

Notice

JOWA USA, Inc. shall not be held liable for errors contained herein or for incidental or consequential damages in connection with the furnishing, performance, or use of this material. The information contained in this document is subject to change without notice.

This document is protected by copyright and all rights are reserved. No part of this document may be photocopied, reproduced, or translated to another language without the prior written consent of JOWA USA, Inc.

Warranty

JOWA USA, Inc. warrants equipment of its own manufacture to be free from defects in material and workmanship under normal use and service for a period of twelve months from date of factory shipment; or if installation is delayed and JOWA USA equipment is stored carefully in its protective packaging for a period of twelve (12) months from date of factory supervised installation, but not later than eighteen (18) months from date of shipment. Equipment not of JOWA USA manufacture is subject to the warranty given to JOWA USA by such manufacturer.

Freight, insurance, or customs costs are excluded and will be billed. Installation labor costs and/or services of a factory engineer are not included in warranty coverage or adjustment. Improper service performed on JOWA USA products claimed to be defective will void warranty.

JOWA USA does not warranty suitability of its product for specific applications, and cannot predict performance or operating life under particular conditions of service. JOWA USA recommends the conduct of field tests, or extended usage under representative conditions, as the only valid means for determining suitability, or for defining operating life and performance in service.

Section I

Introduction

The Petrotape Gauging System and the Chemtape Gauging System is used to measure the liquid level in a tank. This product is used in land-based industrial applications and measures the following types of liquids.

Petrotape

- * Crude oil
- * Petroleum products
- * Petroleum-water mixtures

Chemtape

- * Industrial chemicals
- * Pharmaceuticals
- * Petrochemicals

As an option, the Petrotape or Chemtape sensor may include a single nickel-iron resistance temperature detector or a single 1000 ohm platinum resistance temperature detector. The temperature is measured at a single point that is two feet from the bottom end of the sensor.

The Petrotape / Chemtape may be used in a tank located in an oilfield, at a chemical plant, near a stream, or at a hazardous wastewater holding site. Several Petrotapes / Chemtapes may be used in applications that have multiple tanks, such as a processing plant. This type of system is usually connected to a centralized monitoring system supplied either by JOWA USA or by others.

1.1 Physical Overview

The Major elements of the Petrotape / Chemtape Gauging System are:

- * Sensor
- * Sensor filter
- * Sensor housing
- * Current transmitter

In addition, a customer-supplied still-pipe maybe required for the sensor. Figure 1.1 shows on overview of an installed Petrotape / Chemtape Gauging System.

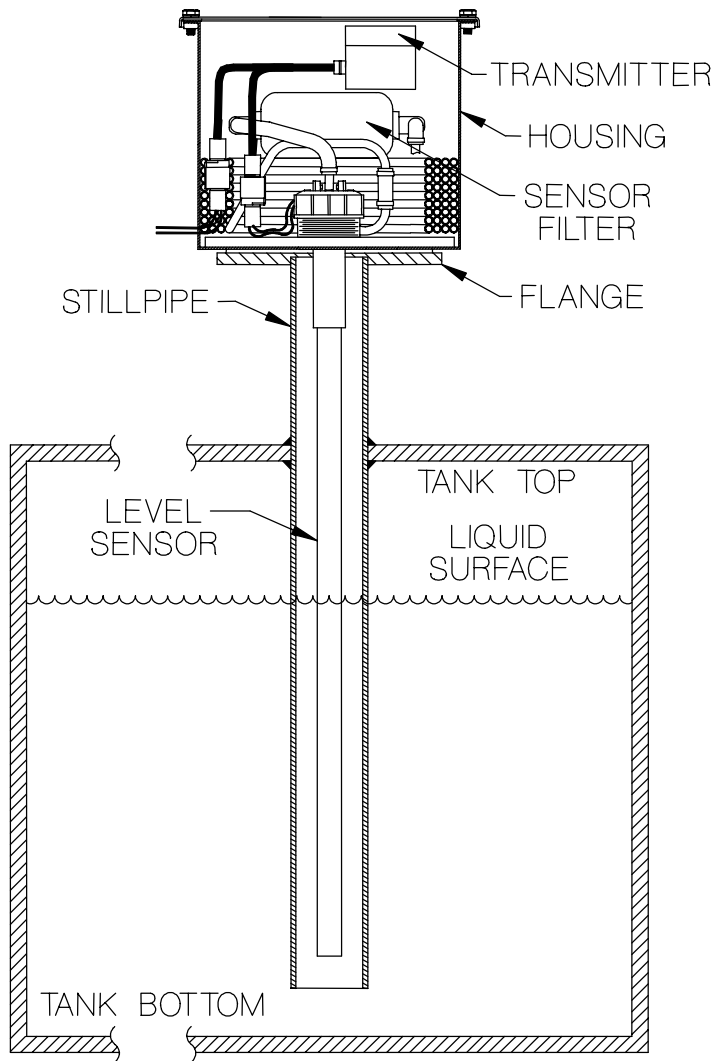

Figure 1.1 Petrotape/Chemtape Gauging System

The sensor and transmitter variations are summarized in Table 1.1 below.

Description	Sensor	Transmitter
Petrotape with level only	PGS/S	T-800L
Petrotape with level and nickel-iron resistance temperature detector	PGST/S	T-800LT
Petrotape with level and 1000 ohm platinum resistance temperature detector	PGSTP/S	T-800LT
Chemtape with level only	CGS/S	T-800L
Chemtape with level and nickel-iron resistance temperature detector	CGST/S	T-800LT
Chemtape with level and 1000 ohm platinum resistance temperature detector	CGSTP/S	T-800LT

Table 1.1 Petrotape / Chemtape System Configurations

Sensor - Used to measure the liquid level. The sensor hangs down into the tank and acts like an electronic dipstick. Figure 1.2 illustrates a cut-away view of the sensor. The sensor structure consists of a stainless steel strip with a gold contact stripe down the center. Film insulation is wrapped around the edges and the back. A nichrome resistance helix wire is wound around this core. The helix is gold-plated, allowing gold-on-gold contacting to occur. The sensor is enclosed by a laser welded Hastelloy C276 or a heat-sealed and compliant jacket of Teflon. A channel has been added to surround and protect the edges, but the total structure remains sufficiently flexible to be coiled on a one-meter diameter reel for storage and shipping.

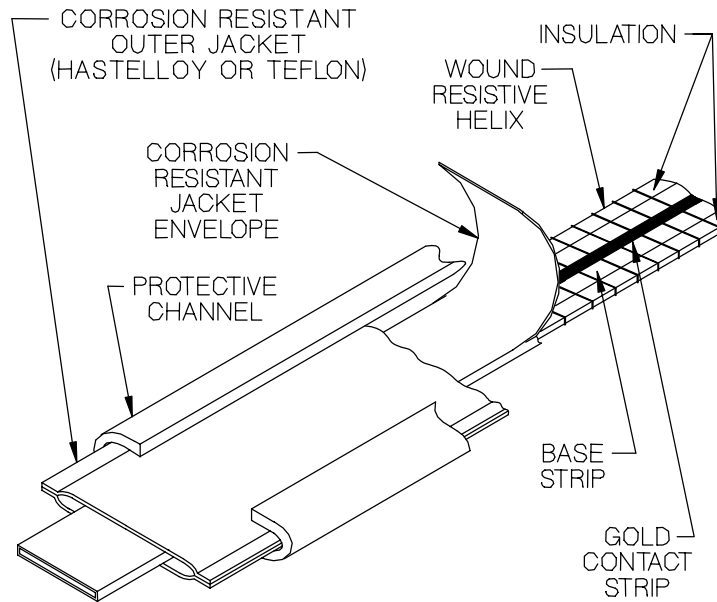

Figure 1.2 Cutaway view of the Petrotape/Chemtape Sensor

Sensor Filter - Used to prevent moisture and other contaminants from entering the sensor and to equalize the vapor pressure within the sensor jacket. The filter is a model PGS/CGS/SF7 and is located inside the sensor housing. Figure 1.3 shows the sensor filter

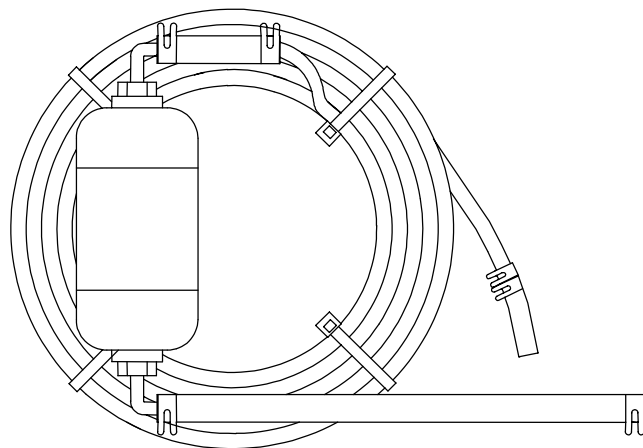

Figure 1.3 Sensor Filter

Sensor housing - Used to mount the sensor head and to house the filter, current transmitter, and wire connections. The sensor housing is a model PGS/CGS/SH887 and is made of 304 stainless steel with dimensions of 8" x 8" x 7". There are four holes which have been bottom punched to mate with a standard 3", 150 psi flange (customer-supplied). The mounting nipple is used to mount and retain the sensor head to the sensor housing. There is a hole located at the bottom of the sensor housing for drainage and another hole on the side of the sensor housing which is used as a conduit for wiring. The sensor housing is shown in Figure 1.4.

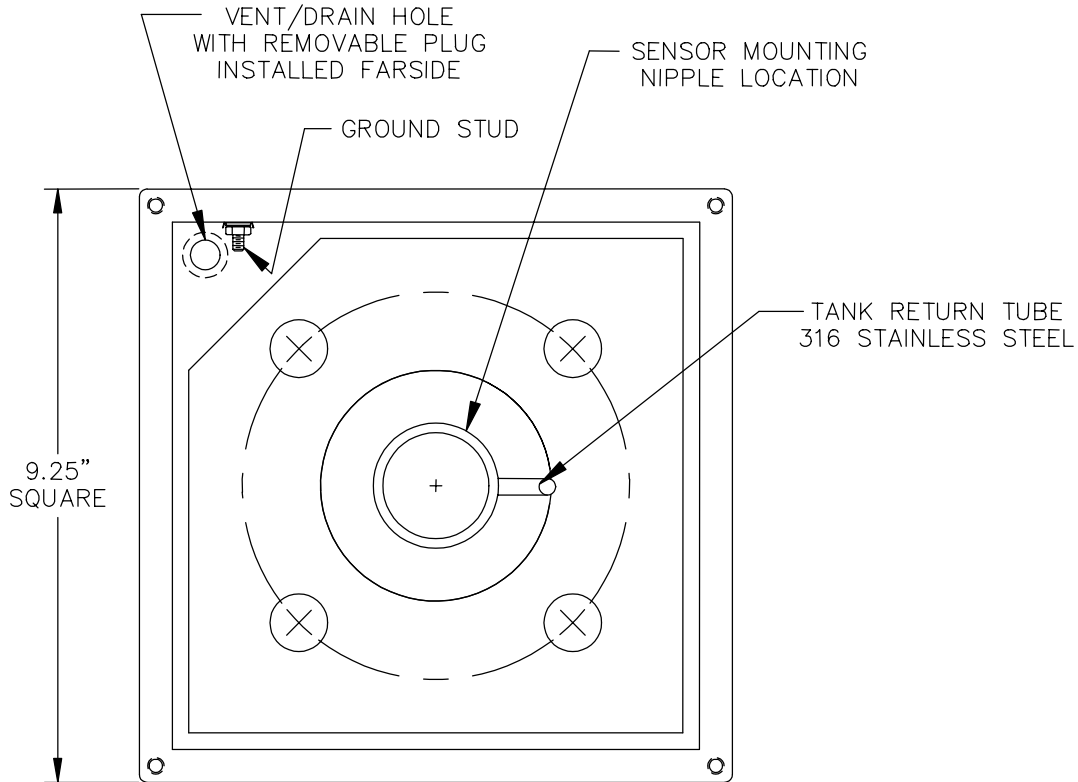

Figure 1.4 Sensor Housing – Top view with cover removed

Current Transmitter - Provides a 4-20 mA current output which corresponds to the liquid level in the tank. The measurement at 4 mA corresponds to a level at the bottom of the tank, while 20 mA corresponds to a level near the top of the tank. The current transmitter is either a model T-800L (level) or a T-800LT (level and temperature). Externally, both types are the same. Internally, the T-800L contains only a level board while the T-800LT contains a level board and a temperature board. The transmitter itself is sealed to protect the internal electronics from moisture or corrosive vapors. The current transmitter is located inside the sensor housing. A current transmitter is shown in Figure 1.5.

Note: If you have a wireless system please refer to the WRT manual, M357.



Figure 1.5 Current Transmitter

Still-pipe (customer supplied) - Protects the elongated portion of the sensor, yet allows free movement of liquid to and from the sensor. A typical stillpipe is shown in Section 2, Figure 2.1.

1.2 Operational Overview

The following sections describe the operation of the Petrotape and Chemtape Gauging Systems.

1.2.1 Sensor

The sensor is suspended vertically from the top to the bottom of a storage tank. As liquid is introduced into the tank and covers the sensor, the pressure of the liquid causes the sensor's sealed outer jacket to collapse. This squeezes the helix against the gold strip, causing a short. The helix is shorted from the bottom end to a location just underneath the surface of the liquid, but the wound helix above the liquid surface remains unshorted. The sensor's gold-plated base steel serves as the return path from the point of uppermost helix contact. The unshorted resistance is the parameter by which the liquid level is measured. This is illustrated in Figure 1.6.

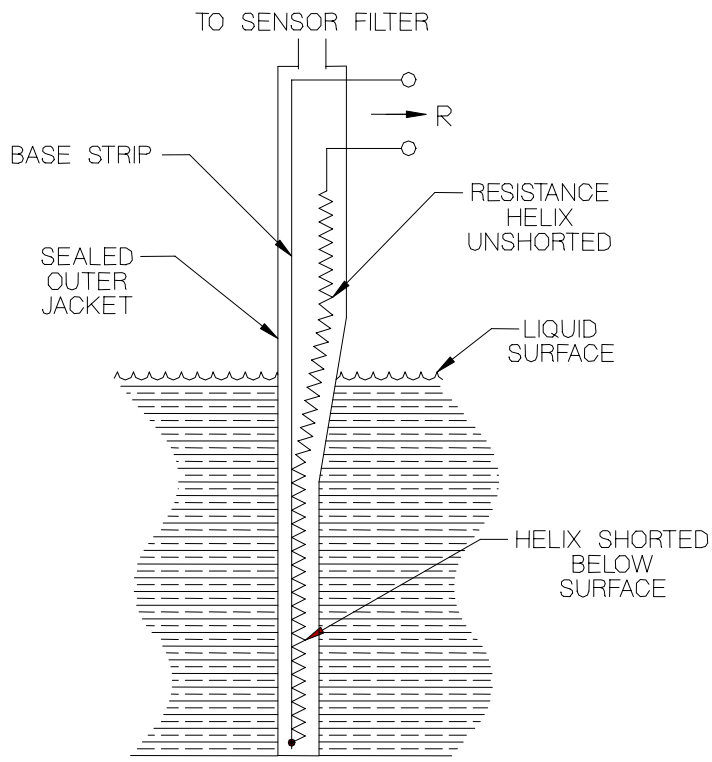

Figure 1.6 Petrotape/Chemtape Sensor Operation

As the level of liquid in the tank falls, the jacket/helix contacts open as they are relieved of pressure and the unshorted resistance increases. The resistance gradient (RG), which is the change in resistance per change in liquid level, is specified on the sensor identification tag. This has a nominal value of 304.8 ohms per foot (1,000 ohms per meter).

The resistance of the helix is measurable across the two leadwires brought out at the sensor head. This resistance is used to determine the level of the liquid.

1.2.2 Current Transmitter

The two wires from the sensor head are connected to the current transmitter. The resistance value from the sensor is converted to the 4-20 mA process current by the current transmitter. This current output is customer-wired to monitoring equipment. The Petrotape and Chemtape sensors with temperature operate in the same fashion except that there are four wires coming from the sensor head; two for level and two for temperature.

The current transmitter is powered over the leadwire pair with nominal 24 VDC excitation.

Note: If you have a wireless system please refer to the WRT manual, M357.

1.2.3 Actuation Depth (AD)

A certain amount of pressure from the liquid is required for helix-to-base strip contacting to occur. This contacting occurs below the liquid surface and is known as the actuation depth (AD). The AD is uniform for any given sensor and is nominally 125 mm for liquids with a specific gravity of 1.000 (water). This is equivalent to a pressure of approximately 0.2 psi. The AD varies slightly from sensor to sensor. The precise AD of the sensor can be determined and offset by the user.

1.2.4 Sensor Filter Operation

The relaxed and uncompressed sensor jacket has an internal gas volume of approximately 0.1 cubic inch per foot of sensor length. As liquid is introduced into the tank, the sensor jacket collapses, and the contained gas volume is exhaled out the tube at the top of the sensor head. Liquid leaving the tank causes the reverse situation. To prevent condensation of vapors and to ensure that only clean, dry air is inhaled into the sensor jacket, a filter is connected to the sensor head.

In addition, if the tank has any vapor pressure other than atmospheric, the sensor filter must be returned to the tank to equalize that pressure. From paragraph 1.2.3 above, it takes only 0.2 psi to close every contact on the sensor.

1.2.5 Temperature Detector

The Petrotape and Chemtape can be provided with an optional resistance temperature detector (RTD). The sensor may have either a 604 ohm nickel-iron or a 1000 ohm platinum RTD.

For the nickel-iron RTD, the average resistance temperature gradient is 1.7 ohm/°F [3.1 ohm/°C]. This gradient can be determined more precisely over a narrow, defined temperature range. Table 4.9 shows the resistance versus temperature values for both RTD types.

Section 2

Site Preparation

Prior to the installation of the Petrotape or Chemtape, the following should be done:

- * Identify the liquid to be measured.
- * Identify the safety concerns.
- * Determine placement of the still-pipe unless using weighted sensor option.
- * Determine whether a baffled washdown is necessary.
- * Prepare and install the still-pipe if required.
- * Prepare for mounting the sensor housing.
- * Review the precautions necessary for installing the sensor.
- * Prepare the field wiring.

These topics are covered in more detail in this section.

Caution

Petrotape and Chemtape sensors should not be installed until all structural, welding, sand-blasting, painting, and pressure-testing operations have been completed. Sensor installation does not require entry into the tank and usually takes a few minutes. Sensors can, therefore, be installed late in the construction cycle and do not need to be subjected to potentially damaging tank preparation procedures.

2.1 Identify the Liquid to be Measured

If the liquid to be gauged is thick, viscous, or has suspended solids consider punching more holes in the still-pipe. Also consider placing the still-pipe in an area where there is enough liquid turbulence to keep the still-pipe flushed out and clear.

2.2 Safety Considerations

When installing a wired system, if the liquid being gauged or its vapors are flammable or potentially explosive, or if the sensor leadwires pass through an area classified as hazardous, an approved zener barrier **MUST** be used to achieve intrinsic safety. When wiring for intrinsic safety, follow the requirements of the Factory Mutual (FM) approved installation drawing A1865900 contained in Appendix A.

2.3 Design of the Still-pipe

The sensor must be installed in a still-pipe when tank contents are agitated. For non-agitated tanks an optional weighted sensor installation may be possible. Consult the factory for additional details and separate instruction provided with the sensor weight when this option is

selected. When using a stillpipe several design criteria should be reviewed and followed and are presented in the following sections. Figure 2.1 shows a typical stillpipe installation.

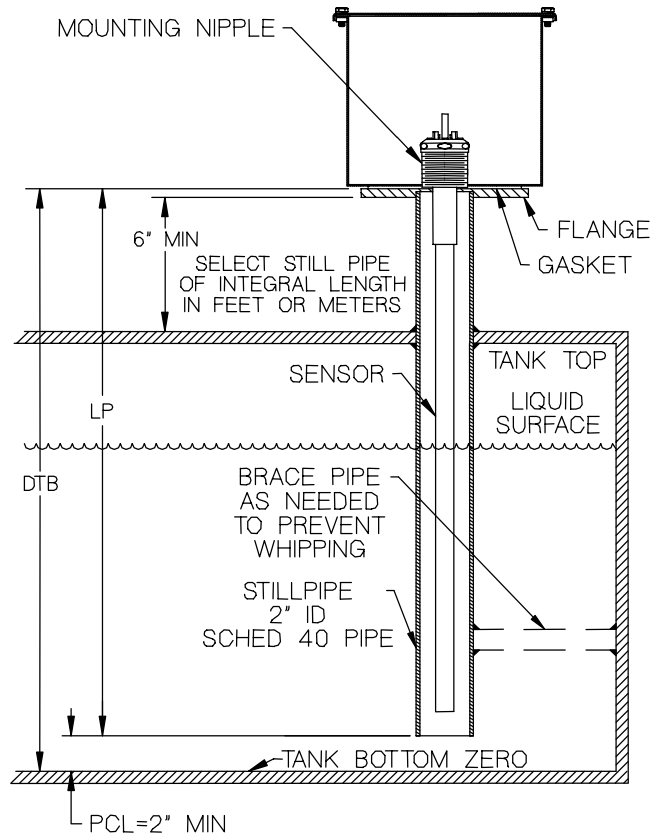

Figure 2.1 Stillpipe Mounting

2.3.1 Still-pipe Location

If the tank has an existing boss or pipe flange that is available, it should be used to mount the required still-pipe. If no tank top penetration exists, it will be necessary to cut a hole in the top suitable for the still-pipe. In general, the still-pipe should be located near the outside wall. This allows the stillpipe to be braced to the inside wall (long still-pipes) and it provides the greatest dimensional stability. When mounted near the center of a tank, the height above tank bottom may vary with tank temperature and pressure.

When selecting the still-pipe location in a tank, remember that adequate room must be available at the tank top where the still-pipe is placed to allow for dispensing the sensor into the still-pipe. A minimum clearance of three feet is required.

2.3.2 Still-pipe Configuration

The still-pipe should be placed in a vertical, straight position in the tank and braced to limit its movement. Short still-pipes (under 10 feet) normally do not need bracing. Longer still-pipes

(up to 20 feet) may also not be braced if there is very little agitation or swirling of the tank contents.

2.3.3 Pipe Material

The still-pipe material is not critical for proper operation of the sensor as long as it does not allow rust or scale build-up. It must be compatible with the liquid or slurry being gauged. Although mild steel is typically used, stainless steel, glass reinforced plastic and PVC have been used.

2.3.4 Pipe Diameter

Either 2" or 3" pipe is typically used. In either case, a 3" 125/150 lb. ANSI flange must be mounted to the top of the stillpipe.

2.3.5 Pipe Couplings

On long still-pipes, couplings will be required to connect sections together. Any type of coupling is acceptable to JOWA USA as long as there are no sharp edges or burrs. If sections are welded together, it is essential that no weld slag, penetrate to the inside of the pipe.

There should be no gaps in coupling that would resist sensor insertion. If there is a gap greater than 0.4" [1 cm] the lower section of the pipe should be chamfered to facilitate installation.

2.3.6 Still-pipe length

The stillpipe length (LP) is the distance from the still-pipe housing mounting flange to the bottom of the pipe. LP should be equal to the height of the tank (at the stillpipe location) plus approximately 1 foot [0.3 meters]. This number should be adjusted higher or lower to come to the nearest integral foot or integral meter length. The still-pipe must extend above the tank top at least 6 inches to allow access to housing mounting bolts.

The still-pipe should be equal or longer than the sensor to provide full protection.

2.3.7 Vent Holes

A pair of opposing 3/4" [19 mm] vent holes must be provided at the top of the stillpipe directly under the tank top. This will prevent an air lock that would not allow the level in the still-pipe to equalize to the level in the remainder of the tank.

2.3.8 Flow Holes

Flow holes at the bottom of the stillpipe are recommended especially if the liquid has any viscosity or if there is a possibility of build-up on the bottom of the tank. They are also required if there may be bottom water (or some other immiscible liquid) on the tank bottom.

2.3.9 Identify Whether a Baffled Washdown is Necessary

A baffled washdown fitting should be considered if the material being measured is apt to leave a residue in the still-pipe and on the sensor. The washdown fitting is used to flush out the still-pipe and any residue on the sensor. Contact the factory for support.

Caution

All inside edges of the still-pipe including holes and couplings must be deburred to remove any sharp or cutting edges which could damage the sensor jacket.

2.4 Still pipe Installation

The still-pipe should extend down to approximately 2" [50 mm] off tank bottom. This will generally allow free flow of liquid in the presence of sand, wax, scale, or other such material build-up. Figure 2.1 illustrates the positioning of the still-pipe. With sensors under 10 feet in length, the bottom clearance may be lowered to 1" [25mm] if there is no possibility of material build-up..

If the still-pipe is longer than 10 feet, it can be clamped to the tank with standard pipe hangers.

2.5 Preparation for Mounting the Sensor Housing

A typical sensor housing mounting is shown in Figure 2.2.

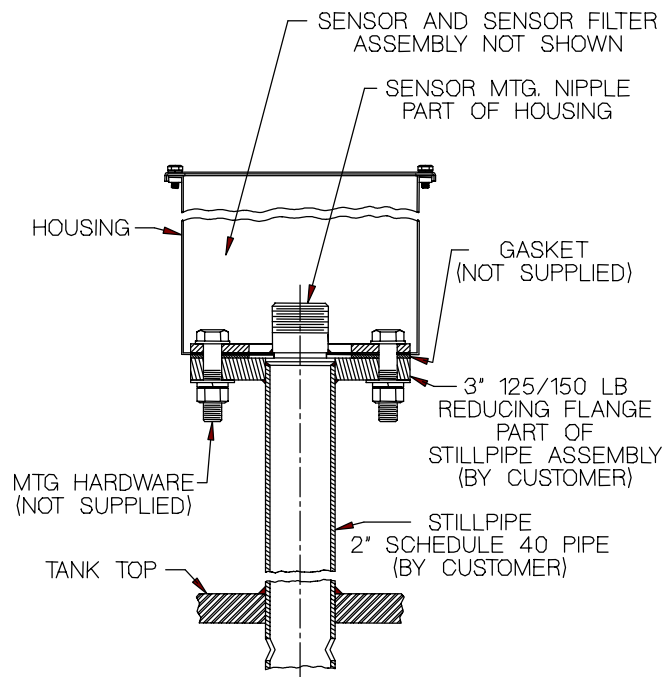

Figure 2.2 Sensor Housing Mounting

The customer-supplied components needed to install the sensor housing are:

- * Gasket - A 3" 125/150 lb. gasket is located between the stillpipe flange and the bottom of the sensor housing.
- * Bolts, Nuts and Washers - Four sets of bolts, nuts, flat washers and lock washers are required to mount the housing to the stillpipe mounting flange. Standard flange and housing holes accommodate 5/8" diameter bolts.
- * Cable entry gland - The sensor housing has a 0.875" diameter hole on one side intended for mounting a standard 3/4" cable gland. thread.

For more information, refer to the engineering drawings in Section 9.

2.7 Initial Electronics Power and Field Wiring – For wireless installation skip to section 3.0

You must determine whether the tank contents, vapors or the area through which the field wire cable must pass is considered a hazardous (classified) location. The National Fire Protection Association document NFPA 497M *Classification of Gases, Vapors and Dusts for Electrical Equipment in Hazardous (Classified) Locations* is one source for this information. If the area is considered non-hazardous proceed to section 2.7.1 and ignore sections 2.7.2 and 2.7.3; if it is considered hazardous, proceed to section 2.7.2 (ignore 2.7.1).

Note that in all of the suggested wiring configurations there is a power supply required. In many cases the power supply is integral to the display device or to the PLC system. This power supply output required for the transmitter is available on a terminal pin designated “Excitation”, “Transducer Power”, “Transducer Excitation”, “+24VDC”, etc. If an external power supply is required, it may be used to power multiple transmitter channels as shown in Figure 2.3.

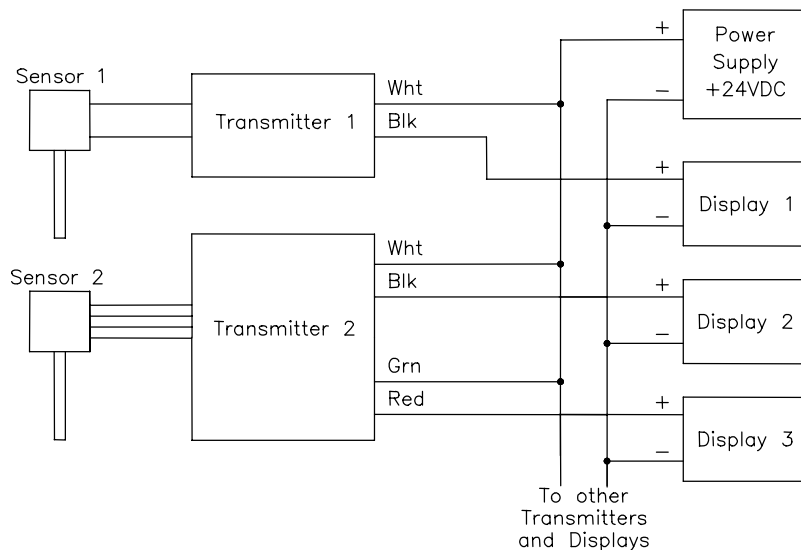

Figure 2.3 Powering multiple transmitter channels

Ensure that the steady state power supply excitation voltage does not exceed 28 VDC (24VDC nominal recommended).

2.7.1 Non-intrinsically Safe Installations

Figures 2.4 through 2.7 show several suggested wiring configurations that are not intended for hazardous locations. You should determine the configuration that matches your requirements. In addition, review the manuals of the instrumentation used with your Petrotape / Chemtape system.

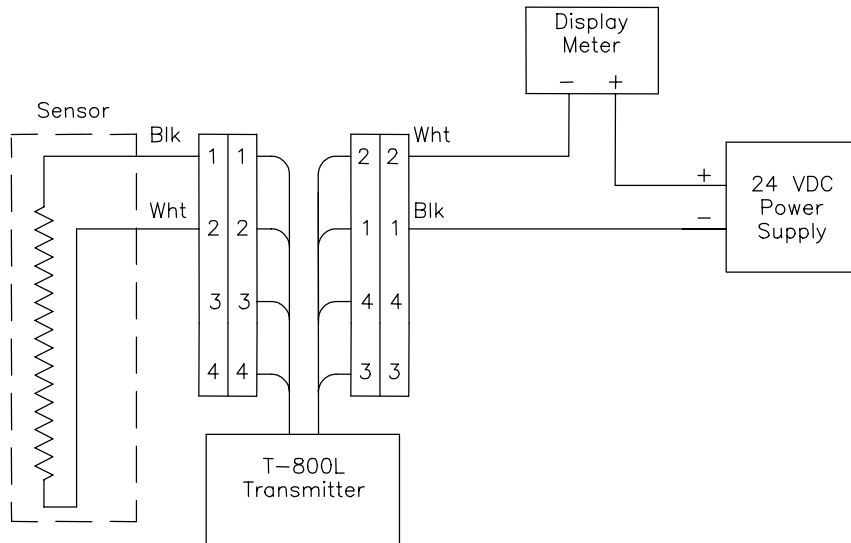

Figure 2.4 Level Wiring to Process Current Display

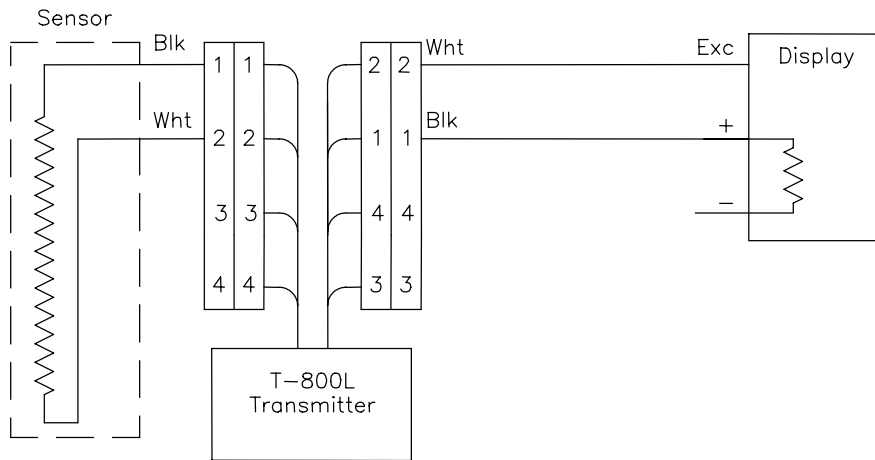

Figure 2.5 Level Wiring to PLC

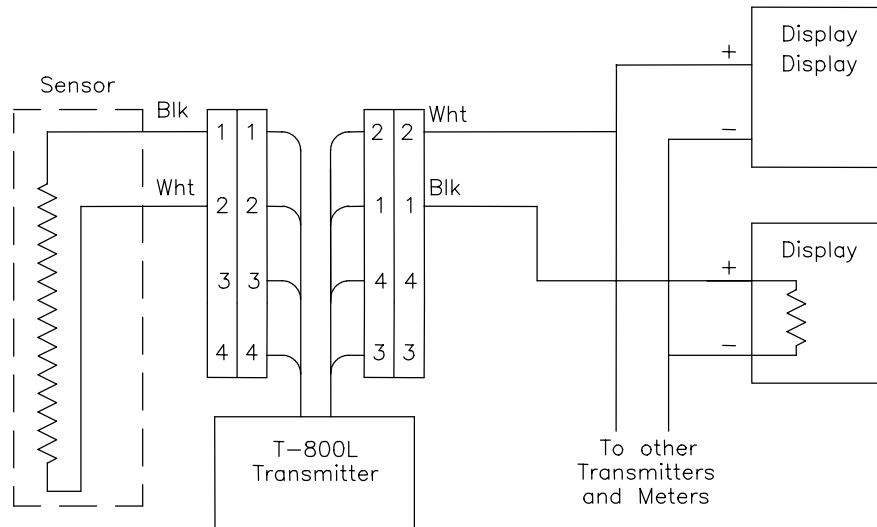

Figure 2.6 Wiring to display with separate power supply

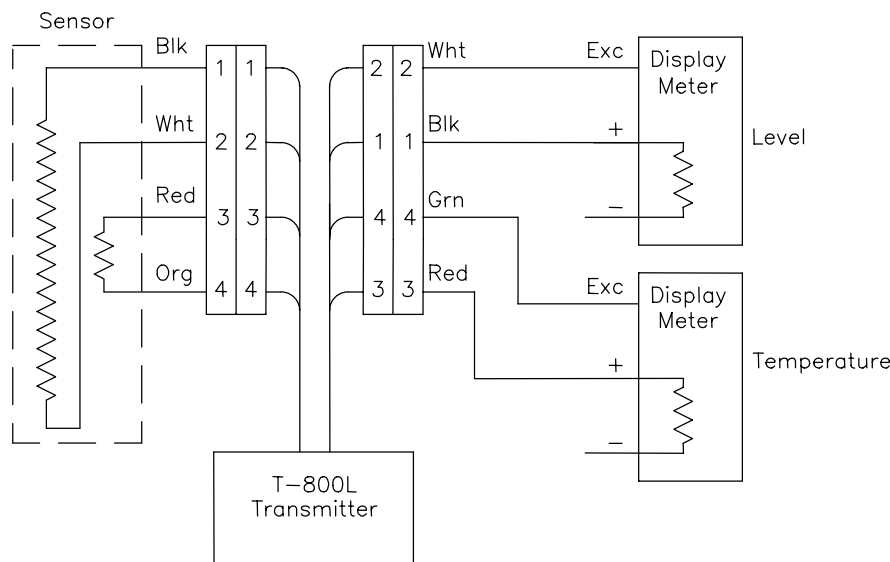

Figure 2.7 Level/temperature wiring to display with excitation

2.7.2 Intrinsically Safe Installations

If the location is considered hazardous, all of the following requirements must be met:

- * For the material being gauged, determine its classification (Class I, Division 1, Group C or D). The sensor and transmitter are not approved for Group A and B materials (Acetylene and Hydrogen).
- * For the material being gauged, determine the autoignition temperature. The sensor and the transmitter both have a temperature rating of T3C.
- * The wiring must meet the requirements of the drawing A1864900 included in Appendix A. This drawing defines all installation requirements that must be met to maintain an approved safe installation.

- * As specified on drawing A1864900, intrinsic safety barriers must be used. JOWA USA US can supply these required intrinsic safety zener barrier in approved enclosures.
- * All wiring must meet the Wiring Practices in ISA / ANSI RP12.6.

Figures 2.8 through 2.12 show several suggested wiring configurations that meet the requirements of the drawing A1864900. You should determine the configuration that matches your requirements.

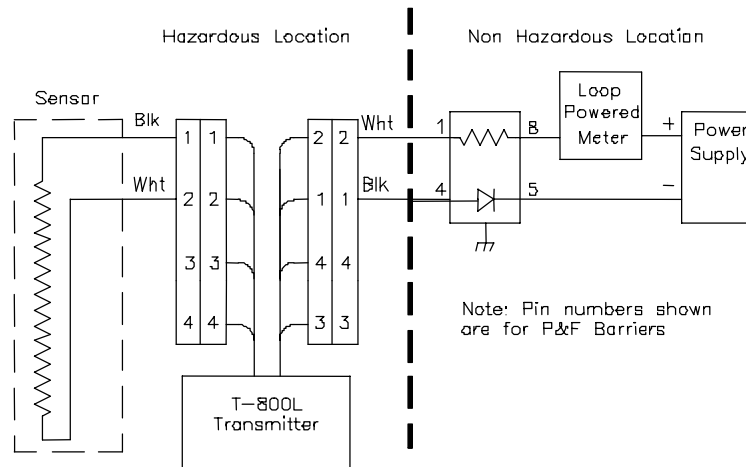

Figure 2.8 Hazardous location wiring to loop powered entity application

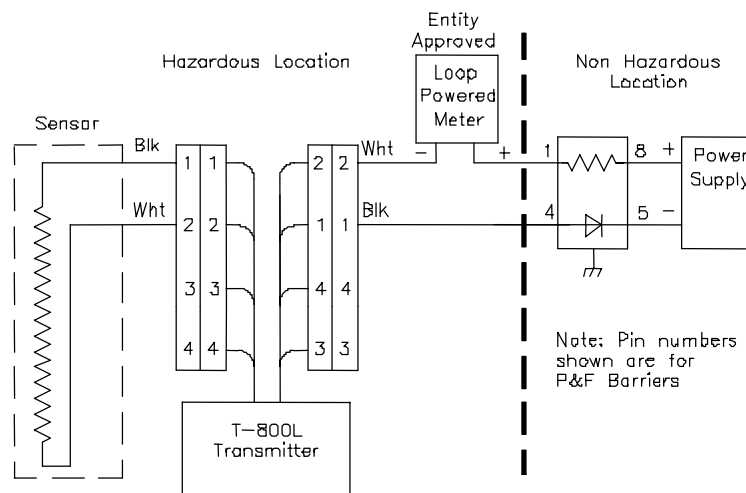

Figure 2.9 Hazardous location wiring to entity approved loop powered meter

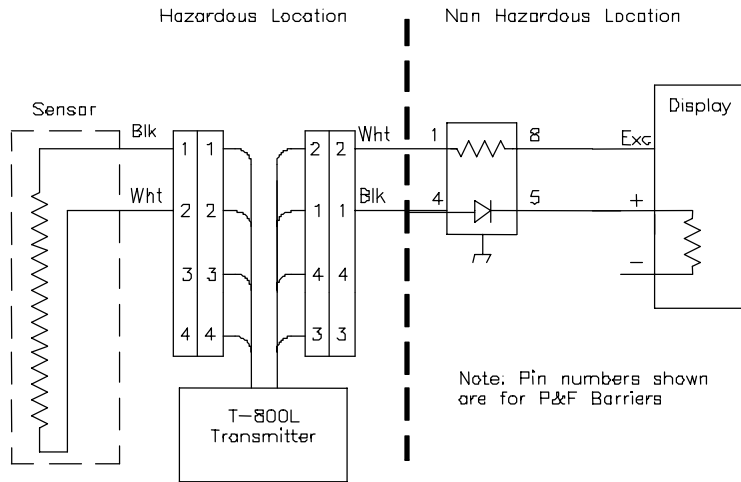

Figure 2.10 Wiring to display meter with excitation

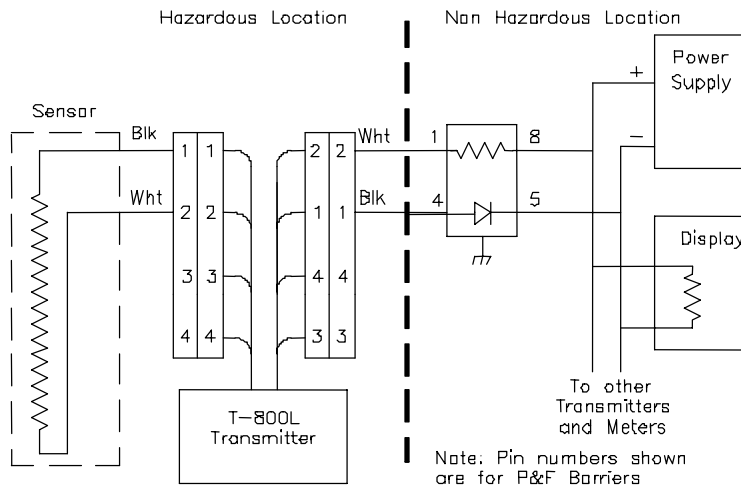

Figure 2.11 Wiring to display meter with separate power supply

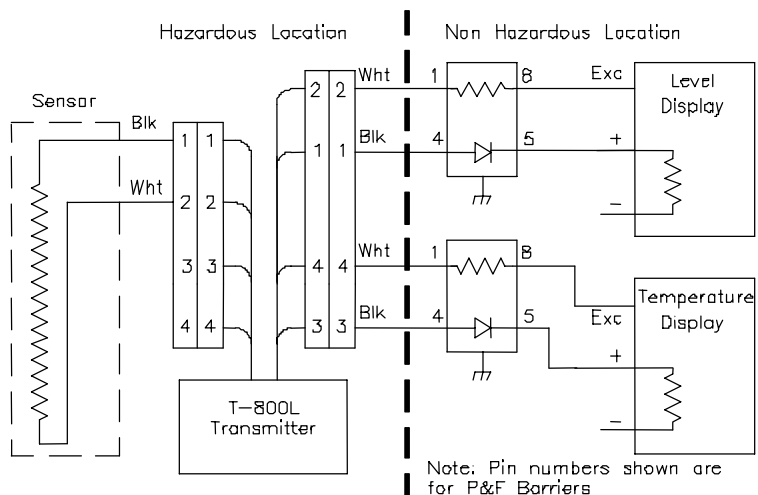

Figure 2.12 Wiring to level/temperature displays with excitation

2.7.3 Entity Configuration

The level-only configurations of Petrotape and Chemtape have been entity approved by FM as shown on sheet 2 of drawing A1864900. Entity approval allows the user to add other entity approved intrinsically components such as loop powered displays to the same current loop. The requirements for entity approved installations are as follows:

Every intrinsic safety barrier is provided with entity parameters:

- * Voc - maximum output voltage
- * Isc - maximum output current
- * Ca - maximum capacitive load
- * La - maximum inductive load

Every entity approved apparatus (including our transmitter) has the following entity parameters assigned:

- * Vmax - maximum allowable voltage
- * Imax - maximum allowable current
- * Ci - capacitance contributed to the loop
- * Li - inductance contributed to the loop

The entity parameters of the T-800L transmitter are shown in Table 2.1.

Vmax	32.0 VDC
I _{max}	120 mA
C _i	0.24 VDC
L _i	0.0 mH

Table 2.1 T-800L Entity Parameters

To properly apply entity parameters, the following conditions must all be met:

- * $V_{max} > V_{oc}$
- * $I_{max} > I_{sc}$
- * $C_i + \text{Interconnection cable capacitance} < C_a$
- * $L_i + \text{Interconnection cable inductance} < L_a$

Note that the 'C_i' above is the sum of the C_i's for all entity devices in the loop and the 'L_i' above is the sum of the L_i's for all of the entity devices in the loop. If the cable capacitance and inductance are unknown, it is acceptable to use 60 pF / foot [200 pF / meter] and 0.2 mH / foot [0.66 mH / meter].

When intrinsic safety barriers are purchased from JOWA USA (MetriBarrier), they are supplied from one of two manufacturers. The necessary data for each of these manufacturers is shown in table 2.2.

Manufacturer	R. Stahl	Pepperl+Fuchs
Manufacturer's P/N	9002/13-280-110-00	Z787
JOWA USA P/N	9122530	9122541
V _{oc}	31.0 V	30.9 V
I _{sc}	109.1 mA	95.2 mA
C _a (Group C)	0.33 mF	0.33 mF
L _a (Group C)	12 mH	16 mH
C _a (Group D)	0.88 mF	0.88 mF
L _a (Group D)	23 mH	32 mH
R _{max}	320 ohms	320 ohms
Return diode voltage (max)	1.0 V	1.0V

Table 2.2 JOWA USA MetriBarrier Data

2.7.5 Transmitter Loop Voltage

The transmitter requires a minimum voltage of 7.5 VDC. This voltage must be available accounting for all voltage drops at maximum current (20 mA) are subtracted including the following;

- * Intrinsic safety barrier resistance (if applicable)
- * Intrinsic safety barrier return diode voltage drop (if applicable)
- * User load resistance
- * Lead wire resistance
- * Minimum power supply voltage
- * Voltage drop of other loop powered entity approved devices.

Typically a +24 VDC power supply will provide more than enough voltage after normal voltage drops are subtracted. To ensure proper operation the following calculation must be made.

$$V_{XMTR} = V_S - 0.02 \times (R_{ZB} + R_{LW} + R_L) - V_{ZB} - V_D$$

where:

- V_{XMTR} = Voltage at the transmitter
- V_S = Minimum excitation voltage from power supply
- R_{ZB} = Intrinsic safety zener barrier series (end-to-end) resistance in ohms (will be 0 if there is no barrier)
- R_{LW} = Lead wire resistance in ohms
- R_L = User load resistance in ohms (frequently 250 ohms)
- V_{ZB} = Intrinsic safety zener barrier voltage drop of return diode (will be 0 if there is no barrier)
- V_D = Sum of voltage drops from any other displays or devices in series with loop.
This voltage drop must be subtracted if these devices are on either side of the intrinsic safety barrier.

EXAMPLE:

As an example, if the transmitter is used with 24 VDC power supply (minimum voltage is 24.0 x 95% = 22.8), a MetriBarrier and a user load resistance of 250 ohms, the minimum transmitter voltage is:

$$\begin{aligned} V_{XMTR} &= V_S - 0.02 \times (R_{ZB} + R_{LW} + R_L) - V_{ZB} - V_D \\ &= 22.8 - 0.02 \times (320 + 0 + 250) - 1.0 - 0.0 \\ &= 10.4 \end{aligned}$$

2.7.5 Shielding

All cables between the sensor housing and the user instrumentation or intrinsic safety barriers should have an overall shield. The shield is best left open at the sensor end and tied either to chassis (earth) ground or signal ground in the instrumentation. The best connection may have to be determined experimentally. In intrinsically safe installations, the shields should be tied to either the IS ground rail (or, if available, to the IS GND connection on the IS barrier).

2.7.6 General

Note the polarity of the loop current (the transmitter is protected but will not operate if the leads are reversed).

All of the field wiring from the instrumentation up to the sensor housing should be completed before the sensor housing is installed.

Section 3

Installation

3.1 Unpacking and Inspection

Installation of the Petrotape and Chemtape systems consists of the following:

- * Unpacking and inspection
- * Pre-installation measurements
- * Installation of housing, sensor, filter, and transmitter

When the Petrotape / Chemtape equipment arrives:

1. Perform an initial inspection by verifying that the boxes are intact and undamaged. If there is external damage to the containers, ask the carrier's agent to be present when the equipment is unpacked.
2. Check the equipment for external damage such as broken components, dents, and scratches. If damage is found, refer to Claims for Damage in this section.
3. Check the cushioning material for signs of any stress or evidence of rough handling in transit.
4. Keep the packaging material in case the equipment must be re-turned.

3.1.1 Claims for Damage

If there is physical damage to the shipping carton or the equipment, contact the carrier and JOWA USA, Inc. JOWA USA will arrange for repair or replacement of damaged equipment without waiting for settlement of the claim against the carrier.

3.1.2 Returning Equipment

A return authorization number is required from the factory before equipment is returned to JOWA USA, Inc.

When returning equipment, attach a tag to the equipment that has the following information:

- * Authorization number
- * Original purchase order number
- * Equipment model number
- * Serial number (if applicable)
- * Owner's name and address
- * Required repair

Pack any piece of equipment being returned in its original shipping container with packing material to protect its surfaces, and then seal the container. If the original shipping container is not available, contact a freight forwarder for an appropriate container and packing material.

3.1.3 Components

The Petrotape and Chemtape Gauging Systems are usually shipped in two containers. One box contains the sensor, and the other box contains the remaining items. Details are as follows:

- * Sensor - Usually shipped on a reel (very short sensor may be shipped straight). Sensors are either packed one to a box or, if three or more have been ordered, they may come in a box that holds up to five reels.
- * Current Transmitter - Packed inside the sensor housing (If wired system ordered).
- * Sensor Filter - Packed inside the sensor housing.
- * Sensor Housing - Packed with the current transmitter and filter inside. The cover of the sensor housing has the securing hardware already attached.
- * Transmitter to field wiring cable.
- * Manual - Packed with the sensor housing.

3.1.4 Storing the Sensor

The operational sensor is designed to withstand harsh operating environments. Outside the still-pipe, however, the sensor may be subjected to a number of hazards, and therefore should be stored away from sharp objects that may damage it. The sensor reels should be stored in a dry indoor area until needed.

3.1.5 Pre-Installation Measurements

Before installing the sensor, measure the tank depth (DTB) from the sensor housing mounting flange to the tank bottom. This is required for instrument calibration.

3.2 Housing, Sensor, Filters and Transmitter Installation

Caution

The sensor should not be installed until:

- * All hot-work and painting in the tank is complete
- * Leadwires are in place (for wired systems)
- * Sensor housing is properly mounted
- * Tank pressure testing is complete

If trouble is experienced with the installation, contact JOWA USA Service to arrange for a consultation with a service engineer

3.2.1 Sensor Housing Installation

The gauging equipment must be accessible and serviceable from outside the tank. The flange, gasket, and bolts are customer supplied. Figure 3.1 details the mounting of the sensor housing.

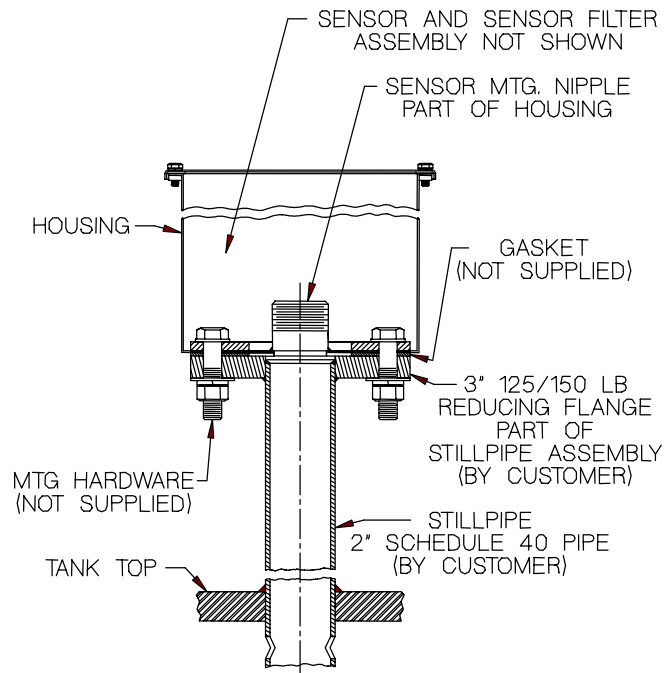

Figure 3.1 Sensor housing mounting

Caution

The sensor housing drainage hole must be kept clear of paint, rust and other materials. If the sensor housing is not properly installed, the sensor housing may be flooded if the tanks are overfilled. Water-tight, gas-tight connections between the housing and the tank are critical.

To install the housing:

- a. Place a gasket (customer supplied) on the still-pipe flange.
- b. Remove the housing cover (set aside the four bolts) and remove the filter and current transmitter located inside the housing.
- c. Orient the housing so that the field wire entry hole is easily accessed.
- d. Mount the sensor housing on top of the gasket.
- e. Bolt (customer supplied) the sensor housing in place.

3.2.2 Sensor Installation

Installing the sensor is accomplished more easily with two people. While one person is handling the sensor shipping reel, the other person can be removing the polyethylene packing sleeve and guiding the sensor through the mounting nipple, into the tank.

Caution

When the sensor is being installed, do not subject it to sharp bends. If it must be bent, the bend must be circular and not less than 3 feet in diameter. Do not cut the ties holding the sensor on the reel.

To install the sensor:

- a. Untie the strings holding the sensor on the reel.

Caution

Do not use a knife or other sharp instrument to cut strings. Avoid twisting or scraping the sensor against sharp edges or rough surfaces.

- b. While carefully removing the sensor clear-plastic packing sleeve (once started, it will tear easily from the sensor), curve the sensor gently and dispense it from the reel into the still-pipe. Refer to Figure 3.2.

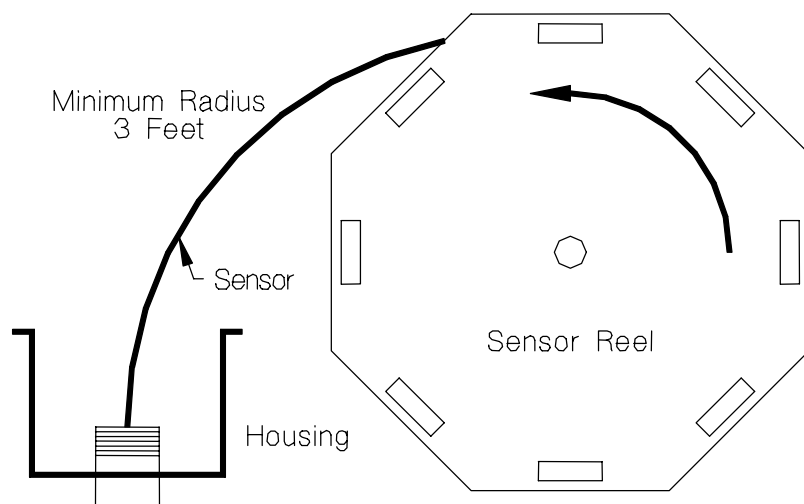

Figure 3.2 Removing the sensor from the reel

- c. If the sensor does not slide easily into the still-pipe, or if it bends or meets an obstruction, do not force it any further. Carefully remove the sensor, correct the problem in the still-pipe, and then try inserting the sensor again.
- d. After the full length of the sensor has been inserted into the still-pipe, the sensor head will rest on the mounting nipple. Make sure the sensor head is properly seated on the mounting nipple and then tighten the mounting ring nut on the sensor head to the mounting nipple.

3.2.3 Filter Installation

The procedure connects the tube from the filter to the sensor head breathing tube. In most cases, the tube from the filter is attached to the housing tank return.

1. Verify that the filter desiccant is functional. Table 3.1 lists the desiccant colors along with the functional condition of the filter.

Color	Filter Condition
Blue	Fully Functional
Pink	Slightly depleted
White	Near exhaustion

Table 3.1 Sensor Filter Color Indicator

2. With the filter desiccant cartridge on top, place the filter so that it surrounds the nipple and sensor head.
3. Remove the protective plug from the inside of the tubing coming from the filter bottle and quickly connect the tubing to the breathing tube on the sensor head by sliding the tubing

over the breathing tube. Make sure that there are no sharp bends or kinks in the tubing. Refer to Figure 3.3.

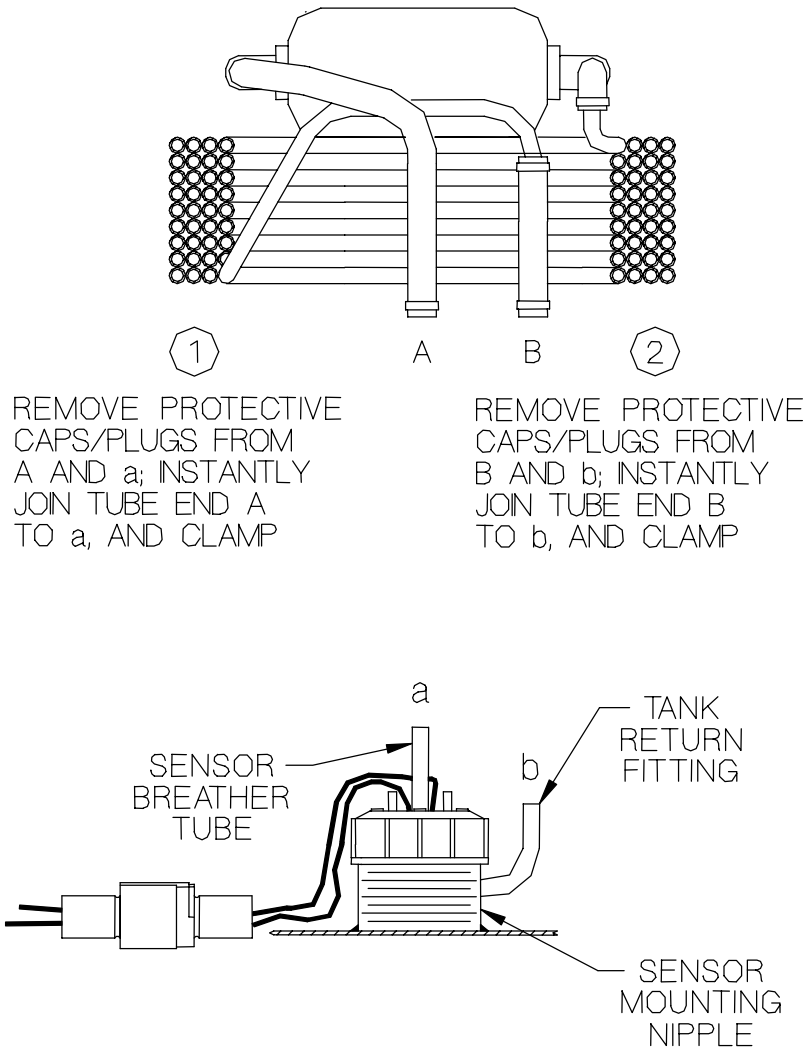

Figure 3.3 Connecting the filter to the sensor

4. Remove the cap from the tank return fitting.
5. Remove the plug from the tubing coming from the tank return end of the filter.
6. If this is a closed tank (operating at positive or negative pressure), connect the tubing from the filter to the tank return fitting by sliding it over the fitting. Make sure that there are no kinks or bends in the tubing.

7. If this is an open tank (at atmospheric pressure), the tubing from the filter and the tank return fitting are normally connected together. If conditions so require, these may be left separated and vented to the atmosphere. Ensure that the vent plug in the bottom of the housing is removed (leave on bottom of sensor housing) and that the filter tank return hose is not sitting on the housing bottom where it might rest in condensation or liquid.
8. Once the filter is attached, the sensor should ingest only clean and dry air.

3.3 Checking the Level Sensor

Several minutes after the filter has been attached to the sensor head breathing tube, the sensor should inhale air and equalize with either the outside atmosphere or with tank pressure, depending on how the tank return fitting has been connected.

During the time that the sensor jacket is being filled with air, the resistance of the sensor should increase slowly until it reaches the RS value indicated on the sensor tag (if the tank is empty), or a fraction of the RS value (if the tank is partly full).

To check the sensor:

- a. Using a multimeter check the resistance of the sensor by connecting the meter leads across the black and white wires coming from the sensor head.
- b. The resistance value should agree (within 2%) with the RS value stated on the sensor tag if the tank is empty. If the tank is full or partially full, the resistance should be approximately 305 ohms/foot [1000 ohms/meter] for each foot [meter] that the liquid is below the sensor head.
- c. If the sensor is low in opening or does not reach its expected resistance value, check for:
 - * Loose filter connections
 - * Obstructions in the filter and its connections
 - * Obstructions or bends in the still-pipe that could cause false contracting of the sensor
 - * Inadequate equalization of tank pressure that could prevent the sensor jacket and helix contacts from opening
- d. If a sensor has been stored on its reel in hot conditions for several months, the sensor jacket can be induced to its normally open position by using light internal pressure of less than 0.5 psi.

3.3.1 Checking the Resistance Temperature Detector (RTD)

If the RTD temperature detector is included on the sensor, check the resistance. The procedure is as follows:

- a. Attach the leads from the multimeter to the red and orange lead-wires at the sensor head.
- b. If the sensor has a nickel-iron RTD (Models PGST & CGST), the resistance should be approximately 675 ohms at 77°F [25°C]. This increases at the positive rate of 1.6 ohms/°F [3.1 ohms/°C]. If the sensor has a 1000 ohm platinum RTD (Models PGSTP & CGSTP), the resistance should be approximately 1096 ohms at 77°F [25°C]. This increases at the positive rate of 2.1 ohms/°F [3.85 ohms/°C].

3.2.3 Cable Connection to Field Wiring Installation

The field wiring is brought into the housing using the field wiring cable.

- a. Feed the field wiring cable through the housing conduit hole using cable gland or cable clamp. Leave the connector inside the housing.
- b. Connect the field wiring to the pigtail leads of the field wiring cable.

3.4 Transmitter Initial Installation – For Wireless System see Manual M332

It is generally recommended that initial calibration be performed 'on the bench' as described in section 4.1. If initial calibration is going to be performed 'on the bench', do not install the transmitter in the sensor housing at this time and proceed to paragraph 4.1.

The current transmitter has two connectors that must be attached. One connector mates with the sensor connector while the other connector mates to the field wiring connector.

To connect the transmitter.

- a. Attach the connector at the sensor head to the connector on the transmitter. The connectors are keyed.
- b. Attach the field wiring cable connector to the other connector on the transmitter.
- c. Place the current transmitter in the upper region of the sensor housing. No fixed mounting is required.

Note

At this point in the installation, the housing cover is still removed pending the calibration which is detailed in Section 4.

3.4 Transmitter Final Installation

- a. Install transmitter cover using screws removed in step 4.5 c. above.
- b. Install housing cover using bolts removed in step 4.5 a. above.

Caution

Ensure that the filter tubing is not pinched or kinked and that wiring does not extend under cover.

Section 4

Calibration

**REFER TO T-800 SERIES CURRENT
TRANSMITTER INSTRUCTION MANUAL
(M323)**

or

**WRT Manual for Wireless Systems
(M332)**

**WHEN CALIBRATION IS COMPLETE, PERFORM
FINAL INSTALLATION PER SECTION 3.4**

Section 5

Maintenance

5.1 Scheduled Maintenance

A properly installed Petrotape or Chemtape should experience neither drift nor wear. It is extremely important, however, to change the filter as required. A typical maintenance schedule is shown in Table 5.1. Adjust the schedule to accommodate equipment usage.

Caution

It is extremely important that the filter be changed at least every three years. If the filter is not operating properly, the sensor will be damaged and require replacement. By the time the filter appears to need changing, the damage to the sensor may have been done already.

Time Period	Equipment	
Yearly Inspection	Filter	Verify that the desiccant chemical is blue. If the chemical is pink or white, replace the filter.
Every 3 years Replacement	Filter	If the filter has not been replaced in the last three years, replace it.
Every 3 years	Stillpipe	Check for silting or other plugging. Be certain that the stillpipe is securely anchored and not damaged in any way.
Yearly	Sensor Housing	Check for evidence of flooding. It should be clean and dry. If necessary, tighten sensor slip nut or filter tank return fitting.
Yearly	Wiring	Check for corrosion of conductors and degradation of insulation.
Depends on application and stability of values.	Sensor	The sensor can be raised from time to time to inspect its physical condition. If it is producing smooth and accurate readings, it is likely to be in good condition.

Table 5.1 Scheduled Maintenance

5.2 Replacement Parts

The specific application of the Petrotape / Chemtape installation determines whether or not spare parts should be kept on site. Since the sensor filter contains desiccant which has a short shelf life, it should not be stored as a spare part; it can, however, be delivered on short notice. Other parts may take several weeks to be delivered.

Model Number	Description
PGS/S	Petrotape level sensor (specify length of integral feet or integral meters)
PGST/S	Petrotape level / temperature sensor (NiFe RTD) (specify length of integral feet or integral meters)
PGSTP/S	Petrotape level / temperature sensor (platinum RTD) (specify length of integral feet or integral meters)
CGS/HPS	Chemtape Hastelloy level sensor (specify length of integral feet or integral meters)
CGST/HPS	Chemtape Hastelloy level / temperature sensor (NiFe RTD) (specify length of integral feet or integral meters)
CGSTP/HPS	Chemtape Hastelloy level / temperature sensor (platinum RTD) (specify length of integral feet or integral meters)
CGS/S	Chemtape Teflon level sensor (specify length of integral feet or integral meters)
CGST/S	Chemtape Teflon level / temperature sensor (NiFe RTD) (specify length of integral feet or integral meters)
CGSTP/S	Chemtape Teflon level / temperature sensor (platinum RTD) (specify length of integral feet or integral meters)
PGS/CGS/SF7	Petrotape / Chemtape sensor filter
PGS/SH887	Petrotape sensor housing
CGS/SH887	Chemtape sensor housing
T-800L	Level current transmitter
T-800LT	Level / temperature current transmitter
SS-904D	Sensor simulator (service and calibration tool)

Table 5.2 Replacement Parts

Section 6

Troubleshooting

6.1 Isolating Faults

The Petrotape / Chemtape is designed to be modular with all the key elements easily separable and, in most instances, plug-in.

The sensor is totally accessible from outside the tank. The sensor leadwires are attached through sealed and keyed connectors, making it virtually impossible to improperly attach them.

If the system appears to be malfunctioning, use these steps to determine the source of the problem and to correct it.

1. Determine whether the problem affects all the tanks (the whole system) or only certain tanks by defining which tank or tanks have erratic values.
 - * If it is the whole system, check the common circuit elements such as fuses, primary power, DC power supplies, shared meters, etc.
2. If only the values for a particular tank are defective or erratic, determine whether the fault lies in the sensor, or in the current transmitter. This is done by disconnecting the sensor leads going to the current transmitter and substitution a sensor simulator or decade box.
 - * If the problem is corrected with the sensor simulator attached, the problem lies in the sensor.
 - * If the problem still exists, the transmitter, wiring or other connected equipment is suspect.

Note

The sensor is a non-repairable assembly and must be replaced if defective. The transmitter may be repaired, but only at the JOWA USA factory.

6.2 Initial System Troubleshooting

If the system has been installed but has never been operating properly, Table 6.1 provides troubleshooting guidance:

Problem	Probable Cause	Remedy
No Current Output from Transmitter	Wiring Error Connector pins pushed in No DC Voltage	Check wiring. Ensure that transmitter current wires are not reversed. Rework as required. Verify that connector pins on transmitter to field wiring connector are not pushed in. Verify that DC power supply is supplying sufficient voltage at transmitter.
Incorrect current output with Sensor Simulator	Improper calibration	Calibrate per Section 4.
Tank level always reads high (current is high)	Sensor Filter not connected or plugged Short in sensor Short in transmitter (sensor side)	Check sensor filter connections. Replace sensor. Replace transmitter..
Tank level always reads low (current is low)	Open circuit in sensor-transmitter cable Open circuit in sensor.	Check connector pins to ensure they aren't pushed in. Replace sensor.
Tank level OK near bottom, faulty near top.	Sensor filter not connected or plugged. Tank vent holes not installed. Improper calibration. Bottom water in stillpipe.	Connect filter Stillpipe <u>must</u> have vent holes just below tank top to prevent air lock. Add holes. Check SPAN calibration. Add more vent holes in bottom of stillpipe.

Table 6.1 Initial System Troubleshooting

6.3 General Troubleshooting

If the level or level / temperature gauging system has been operating properly and has subsequently failed, refer to Table 6.2 for general troubleshooting procedure. The following applies to both level and temperature channels. These tests assume that the system was initially working (i.e. there are now no wiring errors)

Symptom	Probable Cause	Remedy
No current output	Power supply not turned on or not connected. Open field wire	Check voltage Check wiring.
Very large current (>100mA) (over range display)	Failed components due to nearby lightning	Replace Transmitter

Table 6.2 General troubleshooting

6.4 Level Channel Troubleshooting

If the problem with the system appears only to effect the level channel, refer to Table 6.3 for guidance.

Symptom	Probable Cause	Remedy
Level channel current is very low (<2mA)	Sensor to transmitter connector is open	a. Plug in connectors. b. Check pins of connectors to ensure no pins have been pushed in. Pull out pins. c. Sensor has failed open circuit. Replace sensor.
Level output appears 'high' when connected to sensor.	Sensor Filter not connected and equalized	Connect sensor filter.

Table 6.2 Level Channel Troubleshooting

Symptom	Probable Cause	Remedy
Large Current (20 - 30 mA) (Over range display)	Liquid level above 20mA point	a. Lower liquid level b. Recalibrate for wider range
	Short or low resistance in field wires	a. Disconnect transmitter connector from field wiring connector. If short still exists, problem is in field wiring; if not, problem is in transmitter or sensor or their wiring. b. Check connections in sensor housing, redo if bad c. Check cable - replace if bad d. Check connections at instrumentation - redo if bad
Current or display jumps slightly around or near expected value	Waves or ripples on liquid surface	Filter data in display.
	Sensor problem	Put Sensor Simulator or fixed resistor on transmitter input. If current or display is now steady, problem is with sensor or noise pickup with sensor.
Low current (<4mA) (Under range display)	Liquid level is below 4mA point	a. Raise liquid level b. Recalibrate for wider range
	Pins pushed in	a. Verify that pins on both sensor and transmitter connectors are making proper connection.
	Level transmitter leads are open	a. Open connector between sensor and transmitter. Place short between level input pins and verify that current get large. If current does not increase, problem is with transmitter; otherwise problem is with sensor.

Table 6.3 Level Channel Troubleshooting (continued)

6.5 Temperature Channel Troubleshooting

If the problem with the system appears only to effect the temperature channel, refer to Table 6.4 for guidance.

Symptom	Probable Cause	Remedy
Temperature channel current is high (>20mA)	Sensor to transmitter connector is open	a. Plug in connectors. b. Check pins of connectors to ensure no pins have been pushed in.
	Temperature above 20mA point.	a. Lower temperature b. Recalibrate for wider range
	Pins pushed in	a. Verify that pins on both sensor and transmitter connectors are making proper connections.
	RTD open	a. Open connector between sensor and transmitter. Short RTD pins at transmitter input connector. If no response, replace transmitter; otherwise problem is with sensor.
Temperature channel current is low (<4mA)	Short in sensor / transmitter cables.	a. Open connector between sensor and transmitter. If high current goes low, problem is with sensor (check sensor) b. Replace transmitter

Table 6.4 Temperature Channel Troubleshooting

6.6 Sensor Replacement

If the sensor is being returned, it should be coiled onto its reel for shipment. Obtain a return authorization number as described in Section 3.1.2.

The following is the procedure for removing the sensor from the tank.

- a. Remove the sensor housing cover. Save all the housing hardware for reuse.
- b. Disconnect the filter from the sensor head breather tube by sliding the tubing off.
- c. If the tubing from the filter is attached to the tank return fitting, remove it.
- d. Lift the filter clear of its mounting and discard.
- e. Disconnect the sensor leadwires by pulling apart the two black connectors.
- f. Route the leadwires out of the way to prevent damage (tie back if necessary)

- g. Using the old and new sensor data tags, compare the data to ensure that the two are interchangeable. The critical dimension is the over-all sensor length (LS). The two sensors should have the same listed LS to within $\pm 5\text{mm}$.
- h. Select an unobstructed surface area where the removed sensor may be laid down without damaging it.
- i. Unscrew the slip nut at the top of the sensor until it is clear of the mounting nipple.
- j. Grasp the sensor handle nut and pull straight up to ensure the sensor is free to be lifted out of its still-pipe.

Note

The next two steps require two people.

- k. Person 1 - Lift the sensor out of the sensor housing.
- l. Person 2 - Receive sensor head from Person 1 and walk away sensor housing keeping sensor face up. If necessary, coil sensor face out in large (5 foot / 1.5 meter) diameter circle.
- n. Clean the mounting nipple of any remaining product or residue.
- o. Install the new sensor using the procedure in Section 3 and calibrate it according to the procedure in Section 4.
- p. Either discard or prepare for return by:
 - * Cleaning the sensor of any remaining residue
 - * Tying and padding the sensor head
 - * Coiling the sensor with the sensitive side out onto the reel (from the new sensor installed in step o. above) - put sensor head in first.
 - * Carefully winding the rest of the sensor onto the reel.
 - * Tying or taping the sensor to the reel to secure it.

6.3 Filter Replacement

The following is the procedure for replacing the filter.

- a. Open the sensor housing by removing the four bolts at its corners.
- b. Disconnect the old filter from the breather tube on the sensor head by sliding it off the tube.
- c. If applicable, disconnect the tubing from the breather to the tank return fitting by sliding it off the fitting.
- d. Remove and discard the old filter.
- e. Use the procedure in Section 3 to install the new filter.

6.4 Sensor or Pipe Washdown

If the liquid or slurry being measured has a tendency to accumulate on the sensor or in the still-pipe, periodic flushing may be required. This is accomplished using the baffled washdown fitting prescribed for such applications. The application for which the PGS is used will determine the frequency of washdowns.

The procedure for a washdown is as follows:

1. Remove the cover from the washdown fitting.
2. Make sure the baffle is in place.
3. Connect the liquid supply hose.
4. Using water or a mild detergent which is compatible with the sensor jacket system, wash down for a minimum of three minutes using the parameters shown in Table 6.2.
5. Remove the liquid supply hose and cap the washdown fitting.

Parameter	Range
Pressure	5 to 25 psi (35 to 175 kilopascals). DO NOT exceed 15 psi (105 kilopascals) if the wash-down fitting does not have a baffle or diffuser.
Temperature	0 to 160°F (-18 to 71°C)
Flow rate	1 to 5 gallons/minute (0.06 to 0.32 liters/sec.)

Table 6.2 Washdown Parameters

Section 7

Specifications

Specifications for the Petrotape and Chemtape Gauging Systems are listed in the following tables.

7.1 Sensor Specifications

Table 7.1 lists the sensor specifications.

Parameter	Specification
Sensor overall length	3 to 100 feet [1 to 30 meters]
Operating temperature	Petrotape: 5°F to 225°F [-15° to 107°C] Chemtape with Hastelloy jacket: 5°F to 225°F [-15° to 107°C] Chemtape with Teflon jacket: 5°F to 180°F [-15° to 82°C]
Wetted materials	Hastelloy (for Petrotape and Hastelloy jacketed Chemtape) FEP Teflon (for Teflon jacketed Chemtape) Polypropylene head assembly. Protective channel for Chemtape is polypropylene; for Petrotape it is Nylon 11/12
Slip nut	Chrome plated brass
Active helix	Starts 6.3 inches (160 mm) from sensor zero, extends to approximately 1.6 inches (40 mm) from sensor bottom end.
Helix resolution	0.25 inches
Actuation depth	Nominal 7.1 inches [180 mm] head of water; can be calibrated
Specific gravity effect	1% increase in SG causes nominal 1.8 mm increase in indicated level; can be calibrated
Resistance gradient	304.8 ohms/foot [1000 ohms/meter] \pm 1%
Helix resistance temperature coefficient	+40 ppm/°C (nominal)
Frequency response	0 to 0.1 Hz at 1 M amplitude
RTD location	2.0 feet [0.6 meter] from sensor bottom
Sensor weight	22 lb. (10 kg), plus 0.4 lb./ft (0.6 kg/m)

Table 7.1 Sensor Specifications

7.2 Sensor Filter Specifications

Table 7.2 lists the sensor filter specifications.

Parameter	Specification
Filter materials	High density polyethylene, polypropylene and viton.
Filter life	Desiccant life of 12 to 48 months depending on liquid level cycle activity
Pressure / vacuum equalization	Direct equalization over ± 2 psi range.

Table 7.2 Sensor Filter Specifications

7.3 Sensor Housing Specifications

Table 7.3 list the sensor housing specifications.

Parameter	Specification
Size	8" x 8" x 7" [203 mm x 203 mm x 178 mm]
Material	304 stainless steel
Flange	3" 125/150 lb. ANSI
Cable entry hole	0.875" [22.2 mm] (suitable 3/4 conduit fitting)

Table 7.3 Sensor Housing Specifications

7.4 Transmitter Specifications

Table 7.4 lists the transmitter specifications.

Parameter	Specification	Note
Minimum operating voltage (full specifications):	7.5 VDC	
Maximum continuous operating voltage (full specifications):	28.0 VDC	
Maximum continuous voltage:	34 VDC	1
Reverse polarity protection:	34 VDC	1
Transient protection type:	Metal Oxide Varister	
Transient energy level	0.5 joules	

Table 7.4 Transmitter Specifications

Table 7.4 Transmitter Specifications (continued)

Parameter	Specification	Note
Maximum continuous current (non fault):	30 mA	
Level Type:	Innage	
Zero Adjustment (minimum):	800 ohms 2.6 feet [0.8 meters]	1
Zero Adjustment (maximum):	31000 ohms 102.8 feet [31 meters]	1
Zero Coarse Adjustment:	3 position DIP switch	
Zero Coarse Resolution:	3250 ohms 10.6 ft [3.2 m]	1
Zero Fine Adjustment:	20 turn potentiometer	
Zero Fine Adjustment Range	5000 ohms 16.4 ft [5.0 m]	1
Span Coarse Adjustment	3 position DIP switch	
Span Fine Adjustment	20 turn potentiometer	
Linearity	± 0.001% of full scale or ± 0.05"	(2)
Temperature stability	± 0.001 mA/°C ± .005"/°C	
Power supply rejection	± 0.002 mA / VDC	
Damping (-6 dB)	5 Hz	
RTD Types allowed	604 ohm NiFe or 1000 ohm Pt	
RTD Selection	DIP Switch	
Zero Adjustment (Ni-Fe position)	503 ohms to 676 ohms -35°F to 77°F [-37°C to 25°C]	
Zero Adjustment (1000 ohm Pt position)	878 ohms to 1050 ohms -24°F to 55°F [-31°C to 13°C]	
Zero Fine Adjustment	20 turn potentiometer	
Span Coarse Adjustment	2 position DIP switch (4 steps)	
Span Coarse Resolution	69 ohms	
Span Coarse Adjustment (Ni-Fe position)	137 ohms to 414 ohms 87°F to 238°F [46°C to 127°C]	
Span Coarse Adjustment (1000 ohm Pt position)	194 ohms to 588 ohms 90°F to 276°F [50°C to 154°C]	

Table 7.4 Transmitter Specifications (continued)

Parameter	Specification	Note
Span Fine Adjustment:	20 turn potentiometer	
Operating Temperature Range:	-40°F to 140°F [-40°C to 60°C]	
Storage Temperature Range:	-67°F to 185°F [-55°C to 85°C]	
Size	4.5" x 2.5" x 1.6" [114mm x 63mm x 41mm]	
Connector type:	ITT Sure Seal	
Intrinsic Safety Approval	Factory Mutual per 3610	
Intrinsic Safety Rating	Class I, Division 1, Groups C & D	3
Entity Parameters	Vmax	32 VDC
	I _{max}	120 mA
	C _i	0.24 mfd
	L _i	0.0 mH
Temperature Rating	T3C	

Section 8

Terms and Abbreviations

This section contains common abbreviations and acronyms used in the text.

Note

All sensor lengths and distances are measured from the “sensor zero” reference location at the top rim of the sensor head

8.1 Abbreviations and Acronyms Used for Sensor Distances

Terms used in measuring sensor parameters are defined in Table 8.1.

Abbreviation	Meaning
LS	Sensor length from the top zero to end of sensor protective channel.
DTH	Distance to top of helix
DBH	Distance to bottom of helix
N	Sensor housing nipple height from mounting flange surface to top edge. Nominal value is 0.15 ft (44 mm)
AD	Actuation depth - the distance between the liquid surface and the first closed helix. Defined for specific gravity of 1.000; nominal 0.41 ft (125 mm)
DT	Distance from sensor zero to resistance temperature detector.
RS	Total sensor resistance, unshorted
RG	Resistance gradient, rate of change of sensor resistance per unit length
R	Resistance of sensor at measured level
RT	Resistance of temperature detector

8.2 Abbreviations used in Application Parameters

Abbreviations used in measuring application parameters are defined in Table 8.2.

Abbreviation	Meaning
DTB	Distance from stillpipe flange to tank bottom
R4MA	Distance from stillpipe flange to customer 4 mA level
SPAN	Distance from level at 4 mA to level at 20 mA
RZB	Series resistance of zener barrier
HT	Height of Tank - Distance from tank bottom to tank bottom.
SG	Specific gravity of liquid being gauged.

Section 9
Engineering Drawings

This section contains the following engineering drawings:

Note

Only the applicable pages of the drawings have been included.

- * Drawing 1650000 - Intrinsic Wiring for the Sensor (Sheets 1-3)
- * Drawing 1677800 - Suggested Mounting & Flange/Gasket Requirements
- * Drawing 1825001 - Sensor Housing

REV	REVISIONS	DATE	APP'D
A	ORIGINAL RELEASE	7/93	EDC
B	CHANGED PER ECO #1188	2/94	EDC

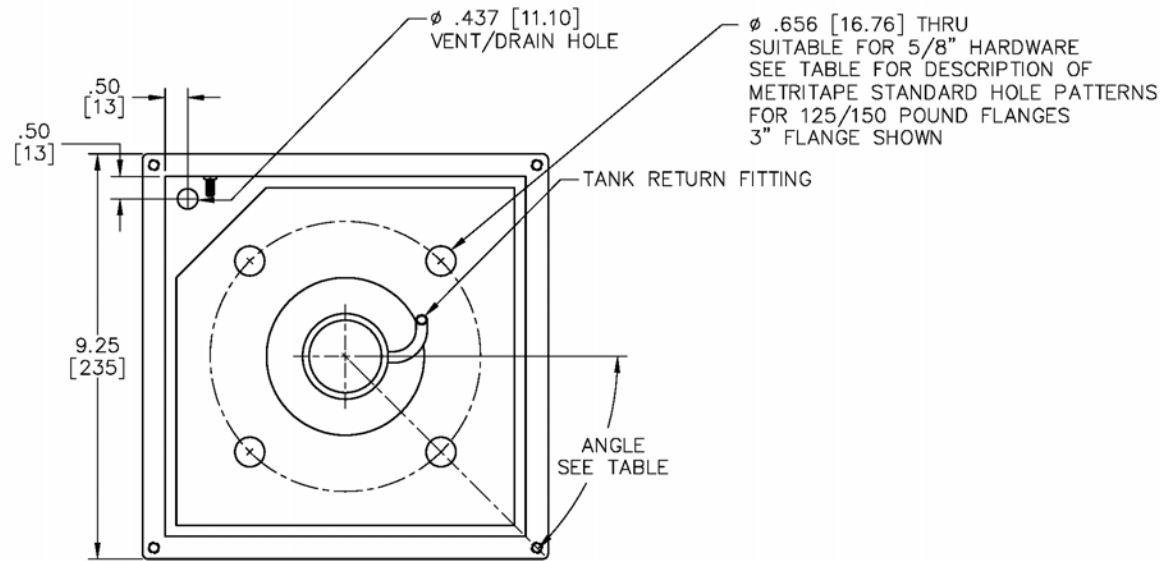

SHOWN WITH COVER REMOVED

NOTES:

- COVER, WITH GASKET AND SCREWS (304 SST) SUPPLIED; MOUNTING FLANGE BOLTS AND GASKET BY OTHERS.
- 3/8" STIFFENER MAT'L: HOT ROLLED STEEL, ZINC PLATED.
- WEIGHT: APPROXIMATELY 15 LBS. [6.4 KG].

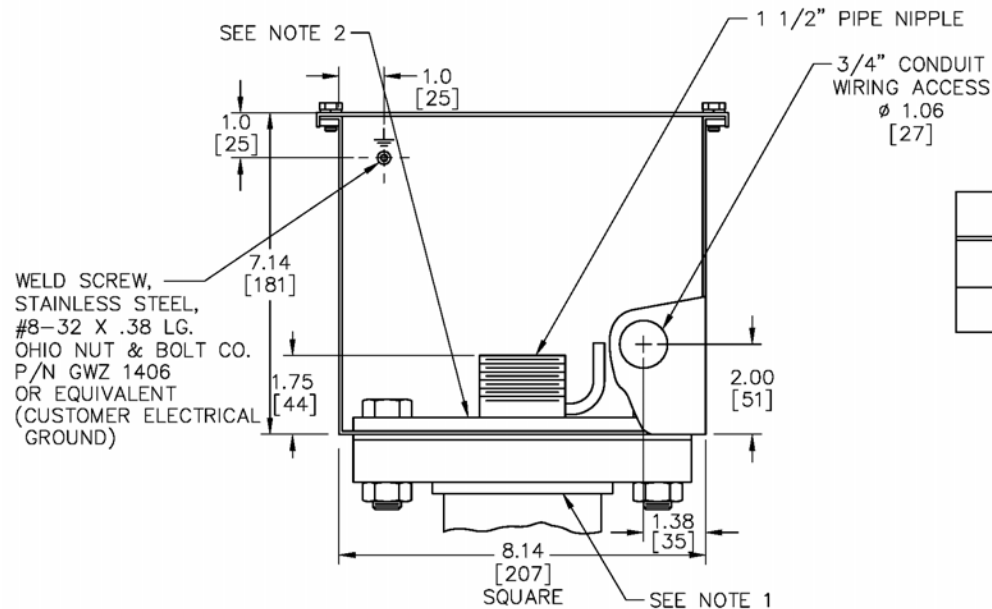

MODEL NO.	METRITAPE PART NO.	MATERIAL SST TYPE	FLANGE SIZE	FLANGE DIA.(REF.)	BOLT CIRCLE	HOLE QTY	ANGLE
CGS/SH887	1688200	304	3	7.5 [190.5]	6.00 [152.4]	4	45.0°
PGS/SH887	1689000	304	3	7.5 [190.5]	6.00 [152.4]	4	45.0°

DIMENSIONS ARE INCHES ALL METRIC DIMENSIONS ARE DERIVED FROM INCHES		JOWA USA	
JWA 000 JWA 210 JWA 005		OUTLINE & MOUNTING CGS & PGS	
DRN: CBS	7/9/93	C	1408802
APP'D: EDC	7/15/93		
NEXT ASSY	USED ON	SCALE: 1:2	REV. B SHEET 1 OF 1

REV	REVISIONS	DATE	APP'D
A	ORIGINAL RELEASE PER ECO # 986	5/93	EDC
B	REV PER ECO #2662	10/98	DAS
C	REV PER ECO #2825	2/02	DAS

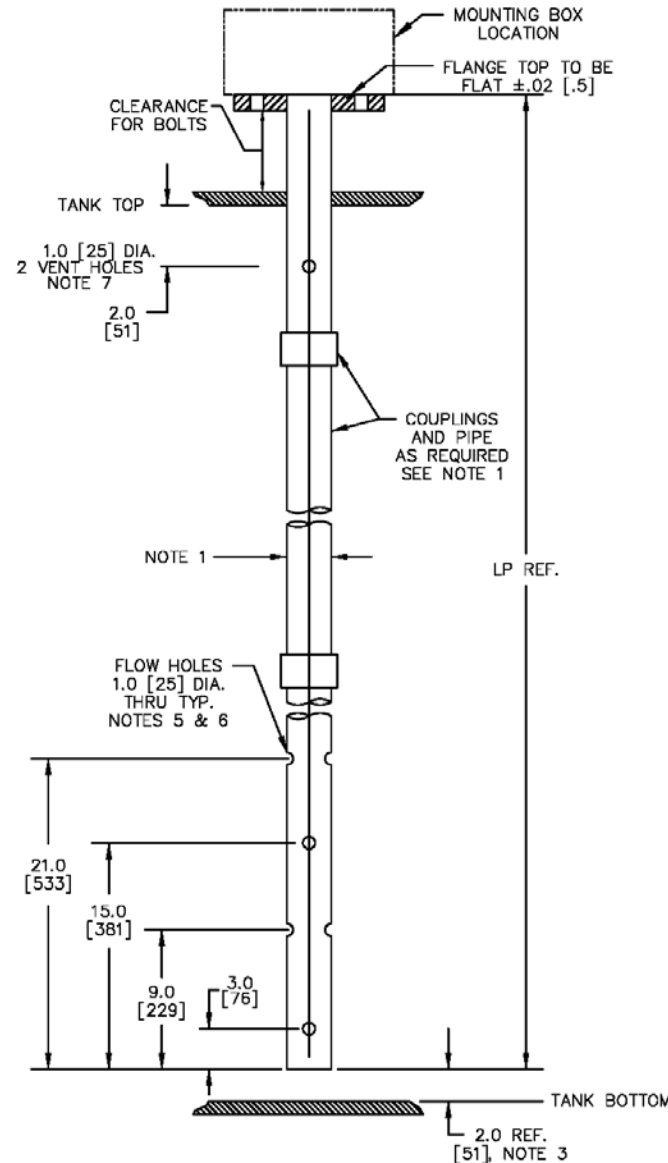

CONSTRUCTION DETAIL

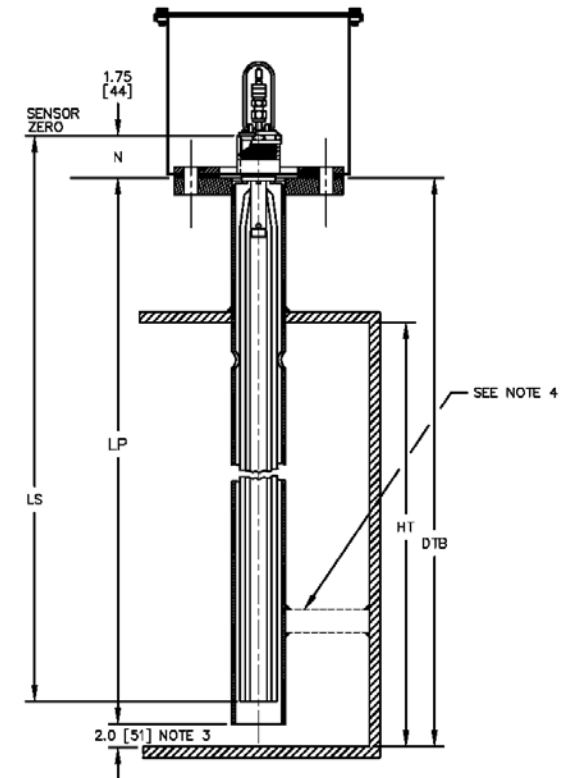

LENGTH DETAIL

- LS SENSOR OVERALL LENGTH (OAL)
- LP STILLPIPE BOTTOM TO MTG. FLANGE FACE
- N NIPPLE LENGTH (MTG. FLANGE TO SENSOR ZERO)
- HT TANK TOP TO TANK BOTTOM
- DTB MTG. FLANGE FACE TO TANK BOTTOM

NOTES:

1. MIN. PIPE I.D. = 1.8 [46], MAX. = 4.0 [101]
2. DEBURR ALL HOLES AND CUTS, INSIDE AND OUT.
3. BOTTOM CLEARANCE RECOMMENDED.
4. BRACE PIPE AS NEEDED TO PREVENT WHIPPING.
5. FLOW HOLES REQUIRED TO ALLOW LIQUID ENTRANCE. VISCIOUS LIQUIDS REQUIRE ADDITIONAL HOLES.
6. IF TANK CONTAINS IMMISCIBLE LIQUIDS, FLOW HOLES MUST EXTEND ABOVE HIGHEST EXPECTED LIQUID - LIQUID INTERFACE.
7. STILLPIPE MUST HAVE A TOP VENT HOLE RETURNING TO TANK JUST BELOW TANK TOP.
8. PIPE MAY BE ATTACHED DIRECTLY TO TANK, AND/OR INSTALLED THROUGH A NOZZLE AND SUPPORTED BY A REDUCING FLANGE. SEE SHEET 2.
9. MAKE MULTIPLE STILLPIPES THE SAME LENGTH FOR CONVENIENT SPARING OF SENSORS.
10. RECOMMENDED LS=LP.

DIMENSIONS ARE INCHES ALL METRIC DIMENSIONS ARE DERIVED FROM INCHES		TYPICAL LANDBASED STILLPIPE FOR CUSTOMER FABRICATION	
USE .020 DIA. PIPES	±.1/2	DATE: DMP 3/25/03	REV: c
DATE: 02/02		QTY: C 1677800	
NEXT ASSY: USED ON	APPRO: EDC 5/24/03	SCALE: NONE	SHEET 1 OF 2

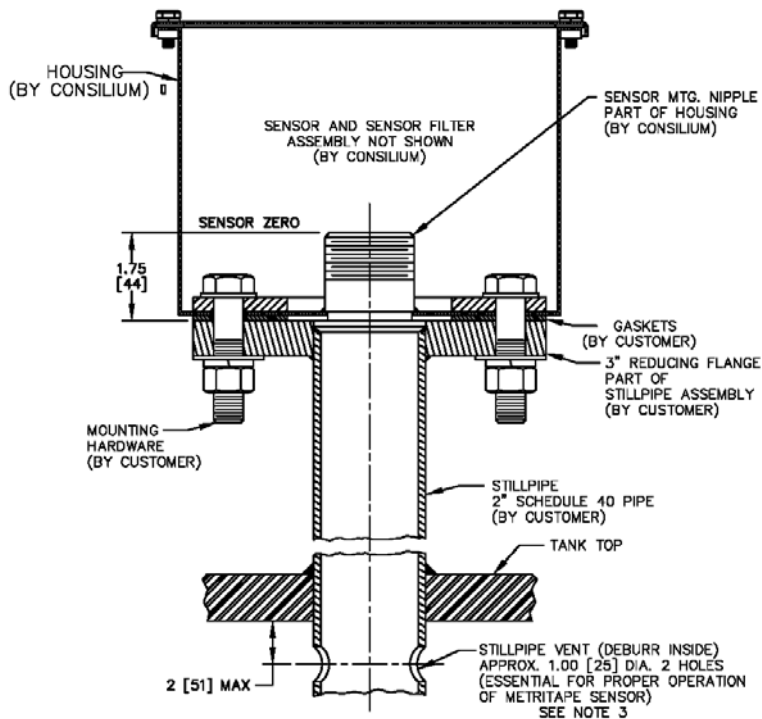

DETAIL
STILLPIPE
TANK TOP

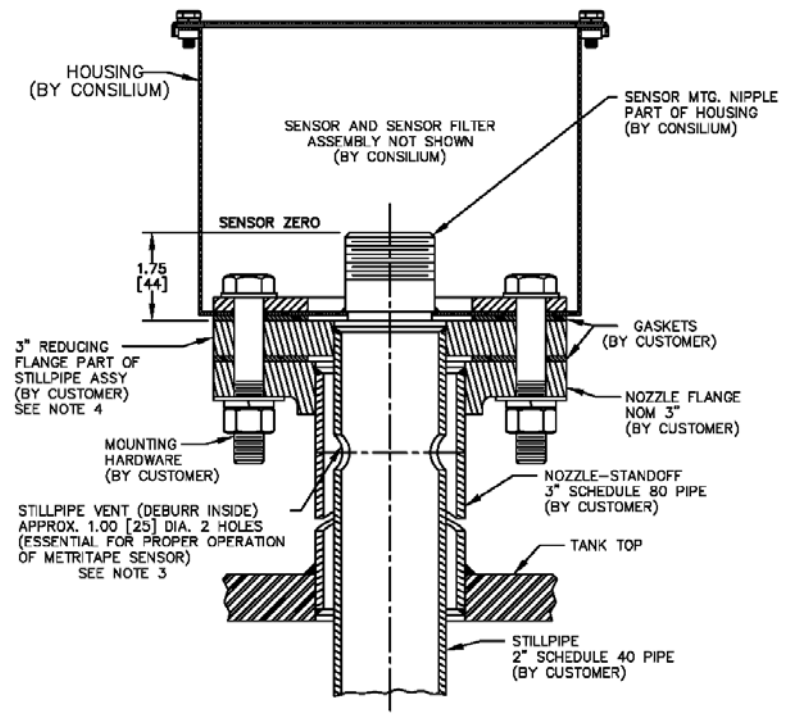

DETAIL
NOZZLE
TANK TOP

NOTES:

1. DEBURR AND REMOVE ALL SHARP EDGES FROM INSIDE OF STILLPIPE.
2. INSIDE OF STILLPIPE TO HAVE NO WELD PENETRATIONS OR PROTRUSIONS.
3. PUT DEBURRED HOLES IN STILLPIPE TO ENSURE LIQUID EQUALIZATION.
4. BOTH SIDES OF REDUCING FLANGE MUST BE FACED OFF.

JOWA USA	
C	1677800
REV	c
SCALE	1:1
PAGE	2 OF 2

REV	REVISIONS	DATE	APP'D
A	ORIGINAL RELEASE	10/92	EDC
B	CHANGED PER ECO# 871	10/92	EDC
C	CHANGED PER ECO# 884	11/92	EDC
D	CHANGED PER ECO'S 1142, 1342	2/94	EDC
E	CHANGED PER ECO# 2326	11/98	DAS
F	CHANGED PER ECO# 2364	1/99	DAS
G	CHANGED PER ECO# 2545	9/99	DAS
H	CHANGED PER ECO# 2612	5/00	DAS
I	CHANGED PER ECO# 3155	12/04	EDC

11	10	9	8	7	6	5	4	3	2	1	REV STATUS
											OF SHEETS

NO REVISIONS WITHOUT FACTORY MUTUAL APPROVAL

DIMENSIONS ARE INCHES ALL METRIC DIMENSIONS ARE DERIVED FROM INCHES		JOWA Consilium				
.X± .020 < ±1/2 .XX± .010 .XXX± .005		RESISTANCE TAPE LEVEL/ TEMPERATURE GAUGING SYSTEM				
		DRN: DAS	8/12/92	A	1650000	REV. I
		CKD:				
NEXT ASSY	USED ON	APPD: EDC	10/8/92	SCALE: NONE	SHEET 1	OF 11

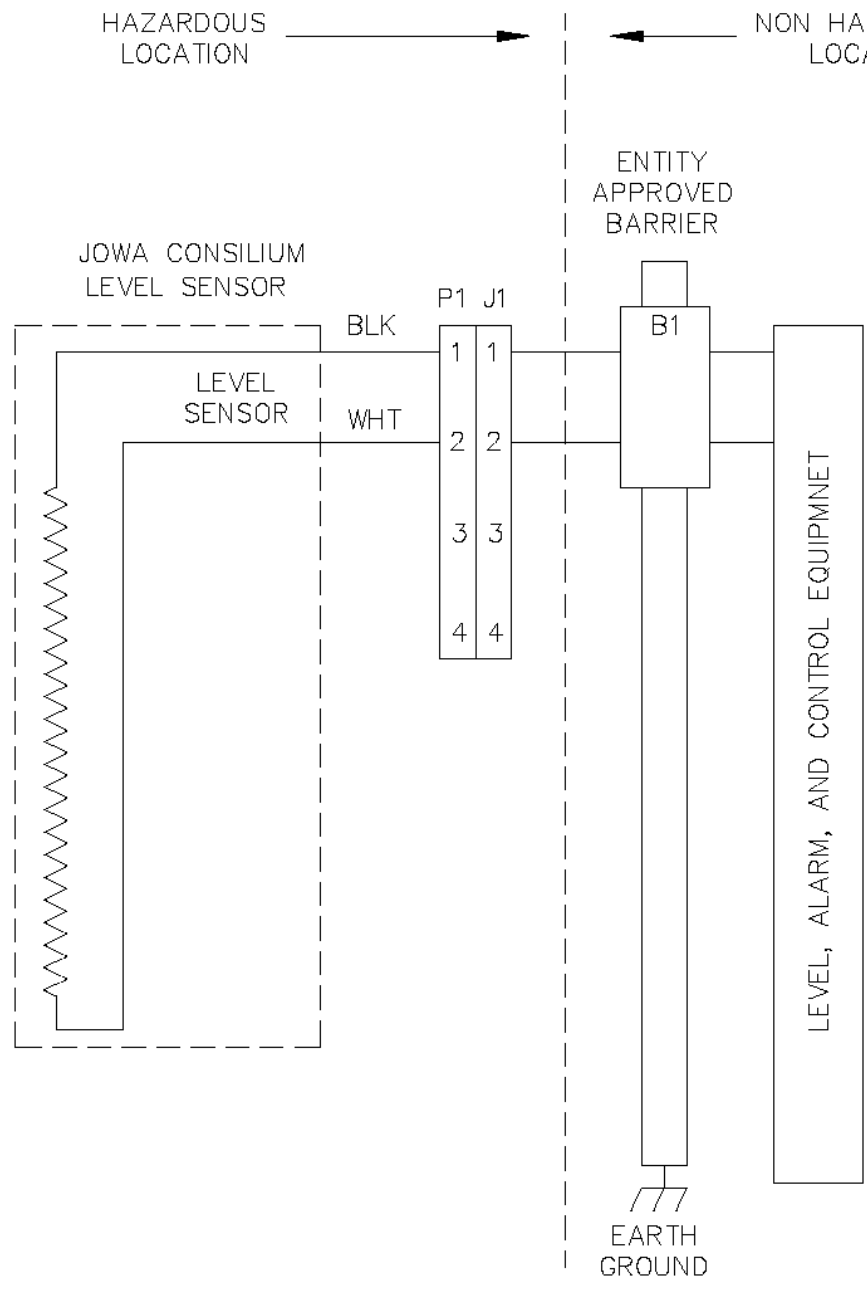

- NOTES
- HAZARDOUS LOCATION CLASS I, DIVISION 1, GROUPS C & D
 - ENTITY PARAMETERS:
 $V_{Max} = 32 \text{ V}$
 $I_{Max} = 200\text{mA}$
 $C_i = 0.01 \text{ }\mu\text{F}$
 $L_i = 0.2 \text{ mH}$
 - ENTITY APPLICATION REQUIREMENTS
 $V_{Max} > V_{OC}$
 $I_{Max} > I_{SC}$
 $C_i + \text{Interconnection cable} < C_a$
 $L_i + \text{Interconnction cable} < L_a$
 - JOWA CONSILIUM LEVEL SENSOR MODELS
 LAacd, LSacd, AGS/S, PGS/fS, CGS/fS
 $a = b, -CR, -AF, -HT, -R, -HN, -HP, -SN, -SP$
 $c = b, (EP)$
 $d = b, (SP)$
 $f = b, HN, HP, SN, SP$
 - THE MAXIMUM VOLTAGE OF THE NON-HAZARDOUS LOCATION SHALL NOT EXCEED 250 VRMS.
 - WIRING SHALL BE IN ACCORDANCE WITH ANSI/ISA RP12.6

ENTITY CONFIGURATION

JOWA Consilium			
	A	1650000	REV. 1
SCALE: NONE		SHEET 2 OF 11	

HAZARDOUS
LOCATION

NON HAZARDOUS
LOCATION

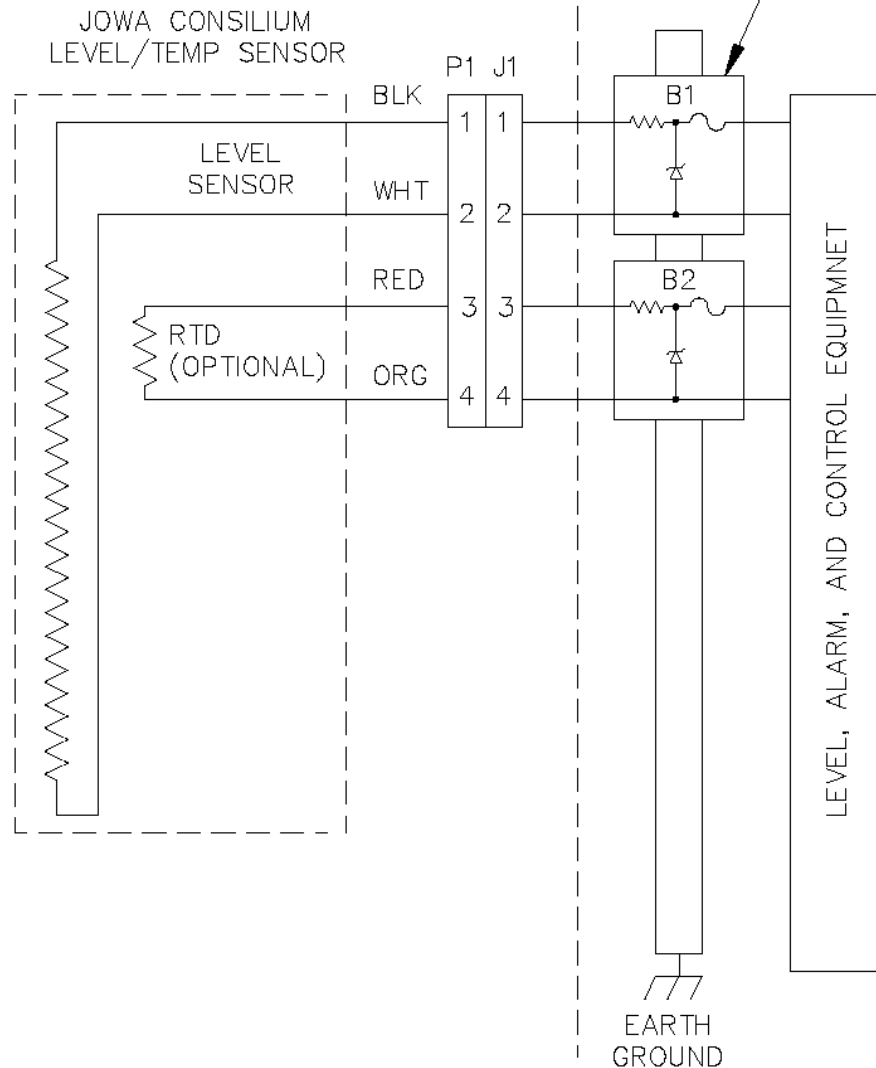

NOTES:

- HAZARDOUS LOCATION CLASS I, DIVISION 1, GROUPS C & D
- THE MAXIMUM VOLTAGE OF THE NON-INTRINSICALLY SAFE APPARATUS SHALL BE 250VRMS
- JOWA CONSILIUM LEVEL/TEMP SENSOR MODELS
 LAabcd, LSabcd, AGSe/S, PGSe/fS, CGSe/fS
 a = b, -CR, -AF, -HT, -R, -HN, -HP, -SN, -SP
 b = b, /TN, /TP, /TC
 c = b, (EP)
 d = b, (SP)
 e = T, TP
 f = b, HN, HP, SN, SP

- WIRING SHALL BE IN ACCORDANCE WITH ANSI/ISA RP12.6
- APPROVED INTRINSIC SAFETY BARRIERS (BI-B2)

MANUFACTURER	MANUFACTURER'S NUMBER	JOWA CONSILIUM NUMBER
R. STAHL INC	8901/31-280/165/80	9122523
R. STAHL INC	8901/31-280/100/70	9122524
R. STAHL INC	9001/01-280-165-10	9122526
R. STAHL INC	9001/01-280-100-10	9122527
MTL INC	728+	9122528
PEPPERL + FUCHS	Z728	9122542

- SEE SHEET 11 FOR BARRIER TERMINAL CONNECTIONS.
- BARRIERS B1 AND B2 SHALL BE THE SAME WITHIN A SINGLE INSTALLATION.
- THE MAXIMUM CABLE CAPACITANCE / INDUCTANCE ALLOWED IS .77uF / 1.7mH FOR GROUP C AND 1.99uF / 3.2mH FOR GROUP D. BASED ON 60pF/FT AND 0.2uH/FT, THE MAXIMUM CABLE LENGTH IS 8500 FT [2600 M] FOR GROUP C AND 16000 FT [4880 M] FOR GROUP D.

SYSTEM CONFIGURATION

JOWA Consilium		
	A	1650000
	SCALE: NONE	SHEET 3 OF 11

REV.
I

