

JOWA USA

DeckMaster IV Level Gauging System



Key System Elements:

- Metritape level sensors with optional temperature detectors
- Deck Unit provides level and alarm indicators on tank top to meet USCG vapor emissions requirements
- Sensor housings used to mount and protect sensors and to make cable terminations
- Central conditioning unit (CCU) with integral flat screen monitor performs signal conditioning, processing and calibration
- Metritape sensors use rugged resistance-tape technology (FM approved for use in hazardous locations)
- Sensors totally accessible from tank top
- Flexible Metritape sensors follow the contour of J-shaped ballast tanks
- DeckMaster IV's program derives the vertical level when stillpipes are curved. It can also compensate for list and trim manually or automatically when draft sensors are included

Features and Benefits:

- Operator can view the level and alarm status of any tank at each deck unit, eliminating the need for common "Christmas tree" alarm status indicators
- Level and volume with optional temperature and inert gas pressure data
- Cargo dedicated, but can also support ballast, service and draft
- Sensors can be mounted in pairs with only one deck penetration to satisfy Independent High Alarm regulations
- Slave deck units may be connected for usage at cargo manifolds
- Optional RS 232 / 485 interface to customer system

DeckMaster IV Level Gauging System

Description:

Barges and coastal vessels with manual on-deck valves require on-deck display of level and alarm status. JOWA is responding to this demand with the DeckMaster IV Level Gauging System, a simple, low cost solution that delivers high performance.

The DeckMaster IV system provides the critical link between JOWA's reliable Metritape level sensors and the Deck Unit.

DeckMaster IV delivers more accuracy than traditional ballast, fuel, and draft gauging methods, resulting in better operational control and more efficient vessel management.

Operating Temperature: CCU electronics 0 to +50°C (refer to sensor data sheets for sensor temperature data); deck unit electronics -30° to +50°C

Output: Optional RS 232/485 serial output protocol may be designed to meet customer requirements

Input Power: 115VAC ± 30% 60HZ, 230VAC ± 30% 60 HZ. Integral power isolation unit converts to 120VAC

Relays: 13 total; 8 level/temp/inert gas pressure, 1 system fault, 2 horns, Form C, 3 Amp at 220VAC, 2 API 100mA at 50VDC

Enclosure: CCU is NEMA12 for indoor mounting, hinged left, coaming cable entry from bottom of cabinet; deck unit is stainless steel NEMA 4 for outdoor mounting

Typical Interconnect Diagram:

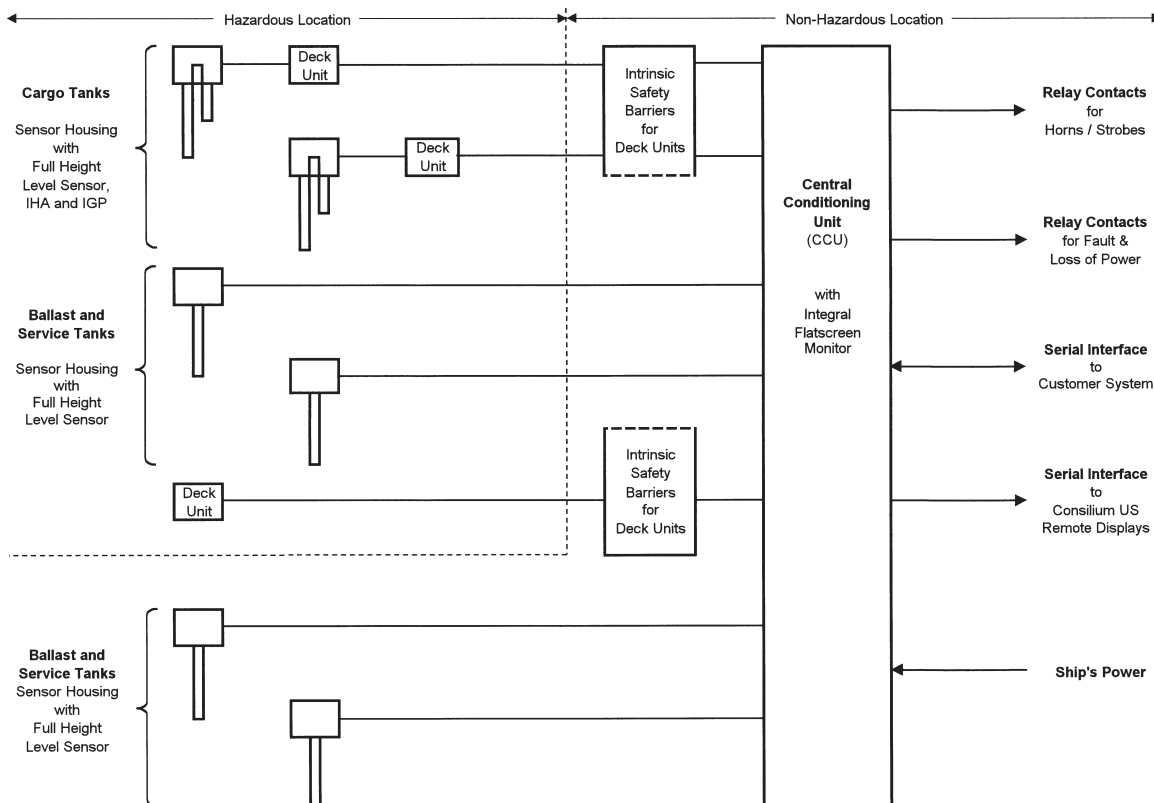

Disclaimer:

This is not a specification and all information is provided in good faith. Since conditions of use are beyond the control of JOWA USA, Inc., the information contained herein is without warranty, whether express, implied or otherwise. Final determination as to the suitability, merchantability or fitness of any information, material or product for a particular purpose, or any patent infringement, is the sole responsibility of the user. JOWA USA, Inc. does not assume liability for injury arising from the use of the information, material or product, and assumes no liability for any damages, whether direct, indirect, consequential, special, incidental, punitive or otherwise. For additional information regarding JOWA USA, Inc.'s limited warranty, refer to the Terms and Conditions that are currently in effect.

JOWA USA

JOWA USA, Inc.

59 Porter Road

Littleton, MA 01460-1431 USA

Tel: 978-486-9800 Toll free: 800-861-1560

Fax: 978-486-0170 E-mail: info@jowa-usa.com