

# JOWA USA

## Metritape™ Level Sensor Type LA

### Features:

- All electric resistance-tape sensor for stable output; no moving parts to stick or break
- Tank top mounted for easy installation
- Virtually maintenance-free; just a 5 minute filter change every 24 to 48 months
- Intrinsically safe; combined level and temperature capability
- Polypropylene, stainless steel

### Description:

The LA level sensor is used for water applications, including fresh and salt water, municipal waste-water, sewage and water-based slurries and suspensions with temperatures up to 60°C (140°F).

The LA sensor is available in overall lengths of 1 to 36 meters (3 to 120 feet). It has a high resolution helix and gold-on-gold electric contacts for 5 mm (1/4") turns resolution and long-term contact stability. The sensor jacket is multi-layer polypropylene, aluminum, polyester (Mylar) laminate with polypropylene as the outermost wetted material. The laminate is protected on three sides with an extruded glass-filled polypropylene channel. The filter assembly protects the sensor from moisture and contaminants and provides pressure equalization.

Temperature detectors can be provided as an option with up to three (3) platinum RTD detectors mounted within the sensor envelope at specified locations.

The LA sensor is not suited for use in chemicals, solvents, or petroleum, in high-vapor-pressure materials, or under cryogenic or high-level nuclear radiation conditions.

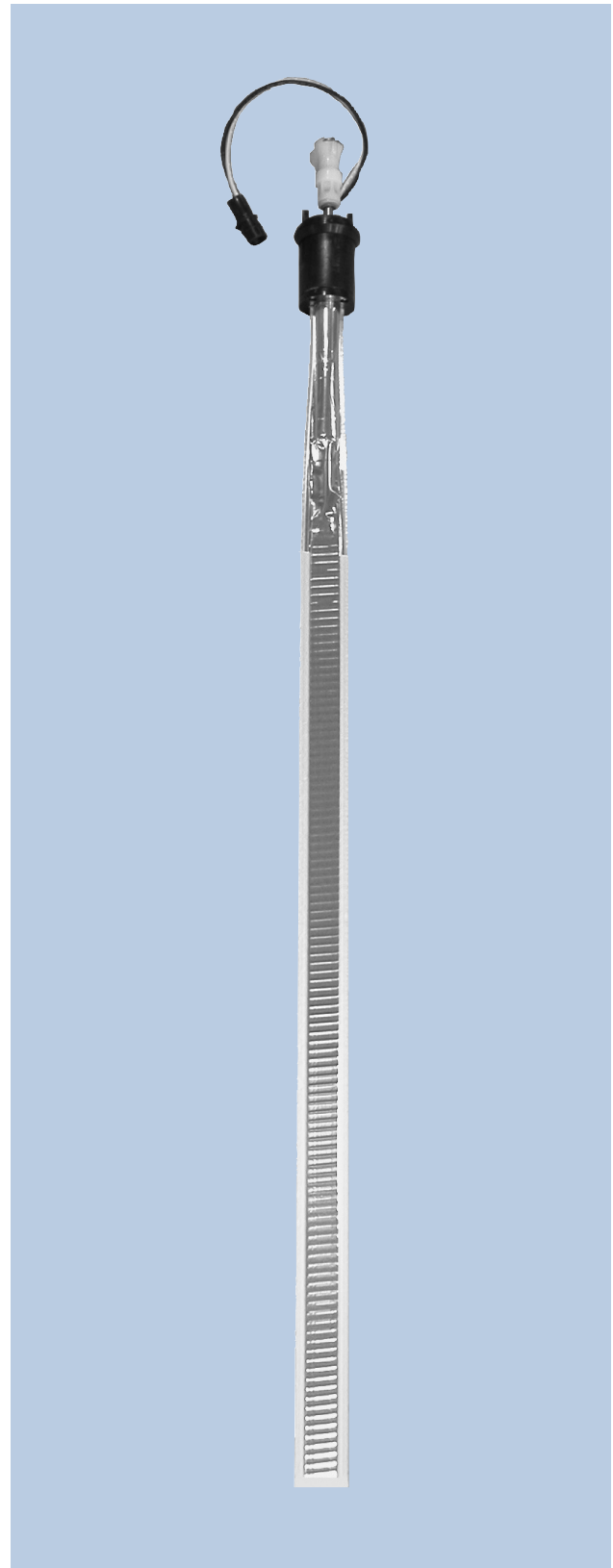

# Metritape™ Level Sensor Type LA

## Operation Principle:

The resistance-tape sensor's outer envelope jacket (1), is compressed by hydrostatic pressure causing the gold plated nichrome wire helix to contact the stainless steel base strip (2). The resulting resistance (3) indicates the length of active or uncontacted helix, and the distance from sensor top to liquid surface.

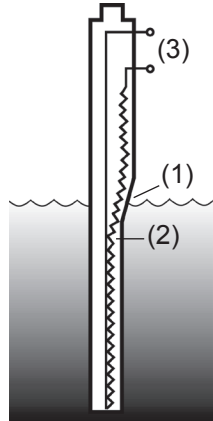

## Installation:

The LA sensor is installed into a customer supplied, vented stillpipe with a minimum inside diameter of 40 mm (1.55 inches). Specific stillpipe construction may vary with application.

**To Specify Length** - (1) Select stillpipe in feet or meters; (2) Specify sensor of same length as stillpipe; (3) LS = LP and stillpipe will extend beyond sensor by 45 mm (1 3/4 inches), the height of close nipple.

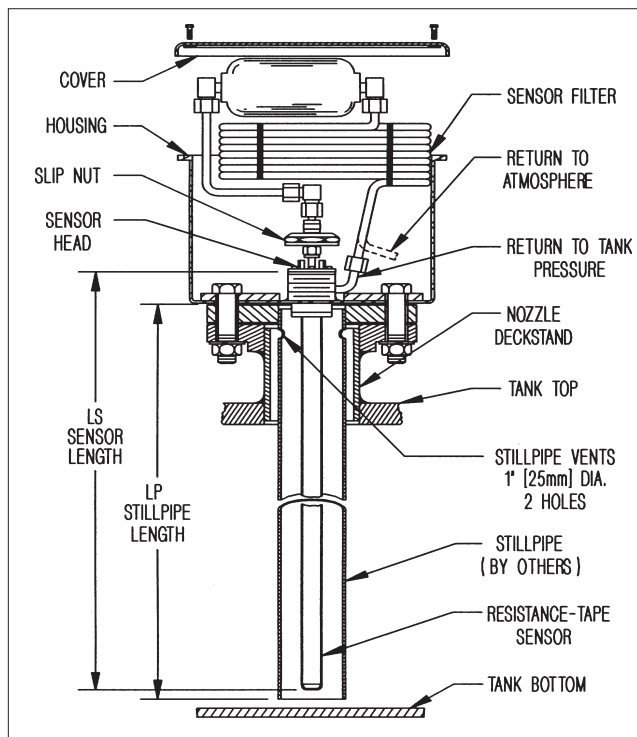

### Disclaimer:

This is not a specification and all information is provided in good faith. Since conditions of use are beyond the control of JOWA USA, Inc., the information contained herein is without warranty, whether expressed, implied or otherwise. Final determination as to the suitability, merchantability or fitness of any information, material or product for a particular purpose, or any patent infringement, is the sole responsibility of the user. JOWA USA, Inc. does not assume liability for injury arising from the use of the information, material or product, and assumes no liability for any damages, whether direct, indirect, consequential, special, incidental, punitive or otherwise. For additional information regarding JOWA USA, Inc.'s limited warranty, refer to the Terms and Conditions that are currently in effect.

## Technical Data:

**Sensor Length:** 1 to 36 meters or 3 to 120 feet.

**Temperature Range:** -15° to 60°C (5° to 140°F).

**Wetted Materials:** Polypropylene, 304 Stainless Steel and Glass-Filled Polypropylene.

**Active Helix:** Starts 270 mm (10.6 in) from sensor zero, extends to approximately 37 mm (1.5 in) from sensor bottom.

**Helix Resolution:** 5 mm (1/4 inch).

**Actuation Depth:** Nominal 145 mm (5.7 inch) head of water, offset at calibration.

**Specific Gravity Effect:** 1% increase in SG causes nominal 1.5 mm increase in indicated level, (can be calibrated).

**Resistance Gradient:** 1000Ω/meter (305Ω/ft), ± 1.5%. Actual value supplied and effect removed at calibration.

**Helix Temperature Coefficient:** 40 ppm/°C.

**Frequency Response:** 0 to 0.1 Hz at 1 m amplitude.

**Sensor Filter:** Polypropylene, HDPE and Acetal. Filter life of 24 to 48 months, depending upon application and level cycle activity.

**Pressure Equalization:** Direct equalization ± 1 atm.

**Temperature Detectors:** Up to three RTDs per sensor, 2-wire 1000Ω platinum (TP). Located .6 m (2.0') from bottom, 3 m (9.8') from sensor top, and at 50% of sensor length.

**Approvals:** When used with approved zener barrier, sensor is intrinsically safe. FM: Class I, Division 1, Groups C, D.

**Sensor Weight:** 0.25 kg (0.55 lb), plus 0.24 kg/m (0.15 lb/ft).

**Sensor Shipment/Storage:** Generally coiled on paperboard reel and packed in corrugated box 107 x 107 x 8 cm (42 x 42 x 3 in.). Packing with reel and box adds 3.0 kg (6.5 lbs.) to sensor weight.



JOWA USA, Inc.  
59 Porter Road  
Littleton, MA 01460-1431 USA  
Tel: 978-486-9800  
Fax: 978-486-0170 E-mail: [info@jowa-usa.com](mailto:info@jowa-usa.com)  
[www.jowa-usa.com](http://www.jowa-usa.com)